

OPTETRAK[®]

A COMPREHENSIVE KNEE SYSTEM

CR/PS

CRUCIATE RETAINING
POSTERIOR STABILIZED



TABLE OF CONTENTS



INTRODUCTION	1
DESIGN RATIONALE	1
OPERATIVE TECHNIQUE OVERVIEW	2
DETAILED OPERATIVE TECHNIQUE	4
PRE-OPERATIVE PLANNING.....	4
APPROACH AND EXPOSURE	4
PREPARATION OF THE FEMUR.....	5
Step 1: Opening the Intra-medullary Canal.....	5
Instrument Setup	5
Step 3: Resection of Distal Femoral Bone	6
Recutting the Distal Femur	7
Step 4: Sizing of Femoral Component	7
Step 5: Establishment of Rotation of Femoral Component	7
Step 6: Resection of Anterior, Posterior and Chamfer Femoral Bone	7
POSTERIOR STABILIZED FEMORAL PREPARATION.....	8
PREPARATION OF THE TIBIA.....	9
EXTRA-MEDULLARY ALIGNMENT	9
Step 1: Placement and Distal Alignment of the Extra-medullary Tibial Alignment Guide	9
Instrument Setup	9
Step 2: Proximal Alignment.....	10
Step 3: Determination of Tibial Resection Depth	11
Step 4: Securing Tibial Resection Guide to Tibia and Final Checking	12
INTRA-MEDULLARY ALIGNMENT	13
Step 1: Opening of the Intra-medullary Canal	13
Step 2: Assembly and Placement of IM Alignment Guide	14
Instrument Setup	14
Step 3: Guide Alignment and Stabilization	14
Step 4: Determination of Tibial Resection Depth	14
Step 5: Pinning of Tibial Resection Guide, Removal of IM Alignment Guide and Final Checking	15
Step 6: Proximal Tibial Bone Resection	16
PLACEMENT AND SIZING OF TRIAL COMPONENTS	16
PREPARATION OF THE PATELLA	17
Step 1: Resection of the Patellar Articular Surface	17
Method 1: Free-Hand Resection.....	17
Method 2: Using the Patellar Resection Guide	17
Step 2: Final Sizing and Drilling of Patella	19
Step 3: Patellar Trial Placement	19
FINAL PROSTHESIS TRIAL CHECK.....	19
Alignment Check	20
Stability Check.....	20
Motion Check.....	20
Patellar Tracking Check.....	21
FINAL BONE PREPARATION: FEMUR	21
Femoral Peg Hole Preparation	21
FINAL BONE PREPARATION: TIBIA	22
Step 1: Fixation of Tibial Tray Trial	22
Step 2: Drilling the Central Cavity.....	22
Step 3: Tamping for Tibial Stem.....	22
PROSTHESIS IMPLANTATION	23
Step 1: Final Bone Preparation.....	24
Step 2: Implantation of Tibial Prosthesis	24
Step 3: Implantation of Femoral Component	25
Step 4: Implantation of Patellar Component.....	26
Step 5: Polymerization of Cement	26
Step 6: Installation of Tibial Polyethylene Insert	27
FINAL CHECK AND CLOSURE	27
INSTRUMENT LISTING	28

INTRODUCTION

Optetrak® is a comprehensive knee system, based on more than 30 years of clinical results from Hospital for Special Surgery, that addresses your concerns for contact stress, patellar tracking, polyethylene wear, joint stability and bone preservation with streamlined instrumentation that lets you work quickly and efficiently.

The Optetrak primary (Cruciate Retaining or Posterior Stabilized) system is compatible with and may be upgraded to the Optetrak Non-Modular Constrained (NMC) or Optetrak Constrained Condylar implants if collateral ligament stability is affected.

DESIGN RATIONALE

In the late 1980s, Dr. Albert Burstein of Hospital for Special Surgery, New York, NY, and Dr. Donald Bartel, a colleague from Cornell University, reviewed the clinical performance of total knee replacements and studied the appearance of retrieved prosthesis specimens. This analysis led them to develop an improved articular design that results in very low Ultra High Molecular Weight Polyethylene (UHMWPE) stresses.

Articular Design

The bi-concave contour of the prosthesis results in reduced polyethylene stress in all loading modes.

The condylar radii have been precisely machined and matched to reduce stress further, while maintaining proven kinematics.

Bone Fit

The bone-mating surfaces have been accurately controlled to assure precise fit.

The implant has seven sizes for both the femoral and tibial components and six sizes for the patellar components, providing anatomical matching of the knee system to bone.

Easy down-sizing of the femoral component allows the surgeon to relieve tight flexion gaps.

Femoral Component

The system includes cruciate retaining, posterior stabilized and constrained condylar options, all with optimized articular geometry.

The bone-mating surfaces are either bead-blasted or porous-coated.

Tibial Component

The articular surface is precisely matched to the geometry of the femoral component.

The modular base plates are supplied with a trapezoid or finned (stem) system; the finned version includes a porous-coated option.

An all-polyethylene and a molded-on-metal back option are available.

Versatility

The system includes stem and augmentation options for both the femur and tibia for revision and special problems and NMC.

Instruments

Instruments supplied with the Optetrak Knee System have been designed to provide the surgeon the tools for accurate and efficient placement of the implant. These instruments allow the surgeon to take full advantage of the advanced benefits of the prosthesis design. Correct placement allows the system to reproduce the normal mechanical alignment of the limb. The instrument system is versatile, yet includes a minimum number of instruments.

Optetrak CR/PS is for cemented use only.

THE OPTETRAK CR/PS OPERATIVE TECHNIQUE WAS DEVELOPED IN CONSULTATION WITH:

Albert Burstein, PhD
Sarasota, Fla.

Donald Bartel, PhD
Iowa City, Iowa

Ivan Gradisar, MD
Akron, Ohio

Gary Miller, PhD
Gainesville, Fla.

William Murray, PhD
Hershey, Pa.

William Petty, MD
Gainesville, Fla.

Hospital for Special Surgery
New York, NY

OPERATIVE TECHNIQUE OVERVIEW

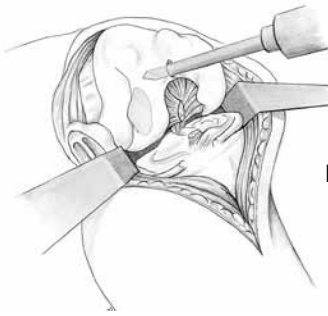

1
**Perforate Femoral
Intra-medullary
Canal**



2
**Setting Distal
Femoral Alignment
Angle**

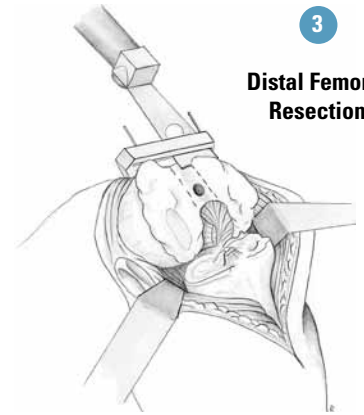

3
**Distal Femoral
Resection**

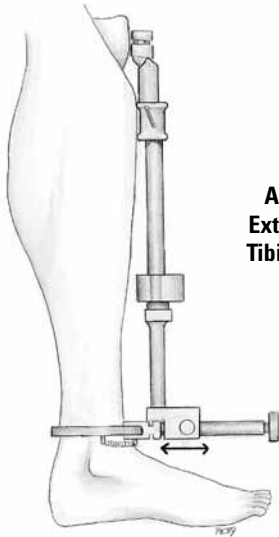

7
**Alignment of
Extra-medullary
Tibial Alignment
Guide**

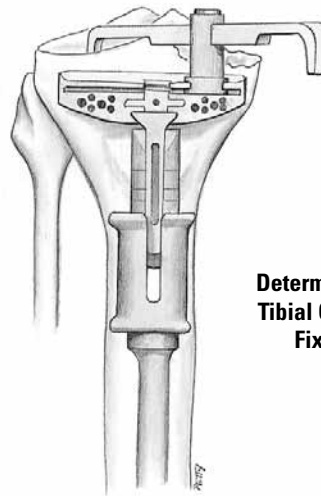

8
**Determination of Proximal
Tibial Cut Depth Using the
Fixed Tibial Stylus**

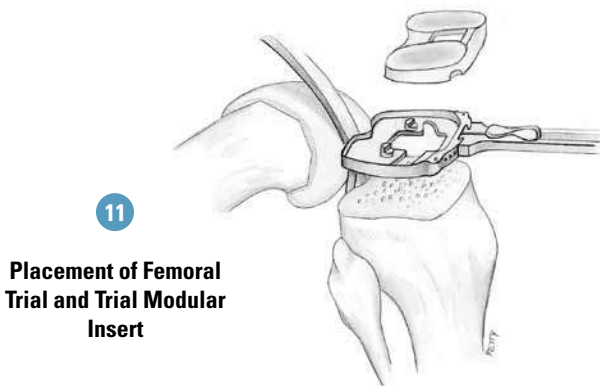
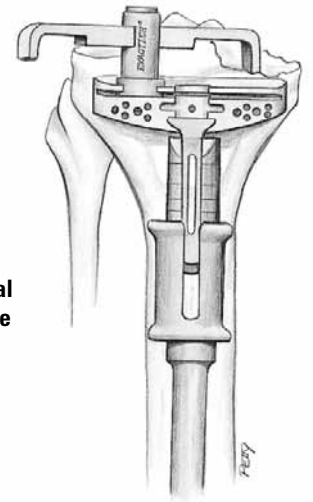

11
**Placement of Femoral
Trial and Trial Modular
Insert**

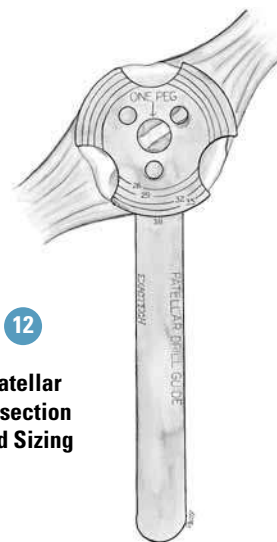
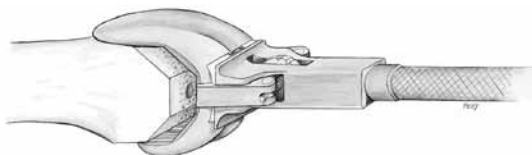

12
**Patellar
Resection
and Sizing**

13
**Trial Reduction and
Assessment
of Alignment and
Tibial Rotation**



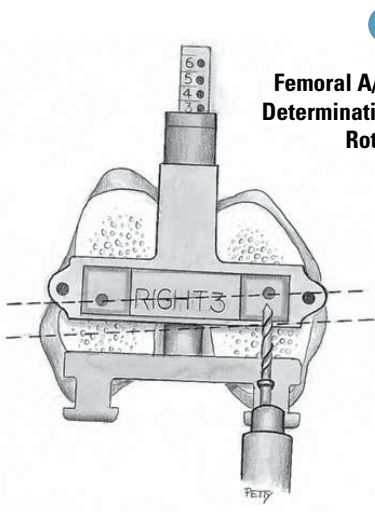

4

Femoral A/P Sizing and Determination of External Rotation

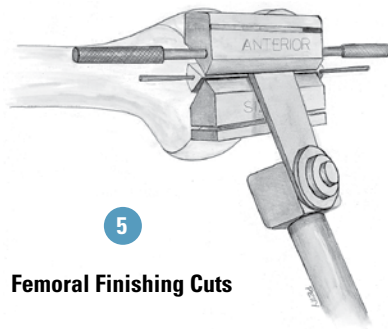

5

Femoral Finishing Cuts

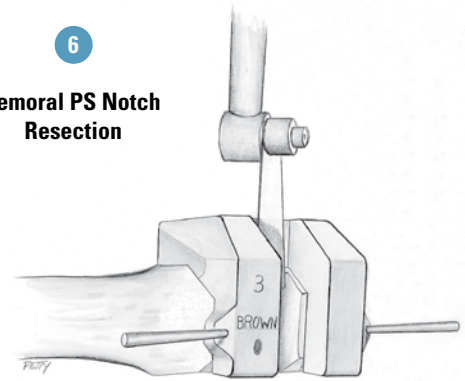

6

Femoral PS Notch Resection

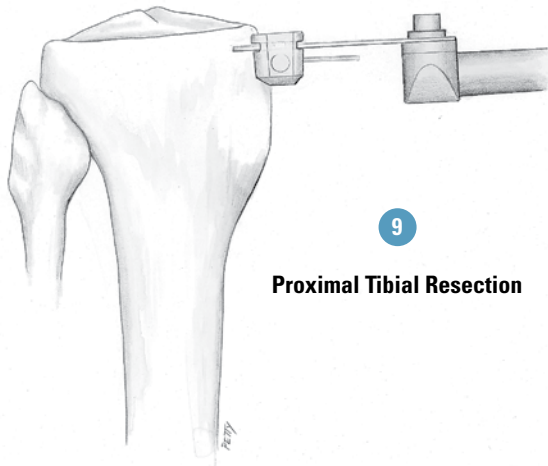

9

Proximal Tibial Resection

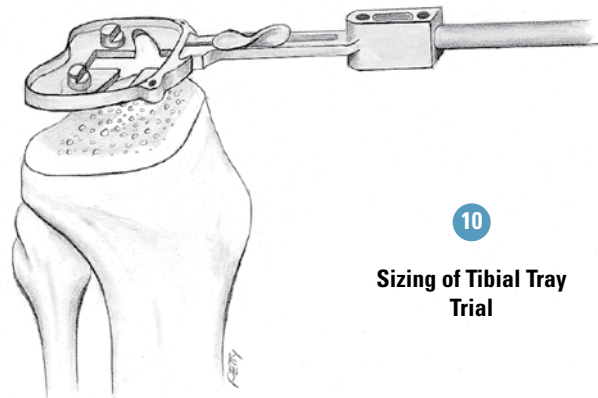

10

Sizing of Tibial Tray Trial

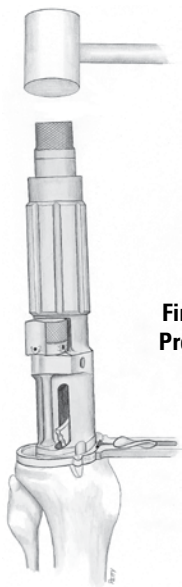

14

Final Tibial Preparation



15

Cementation

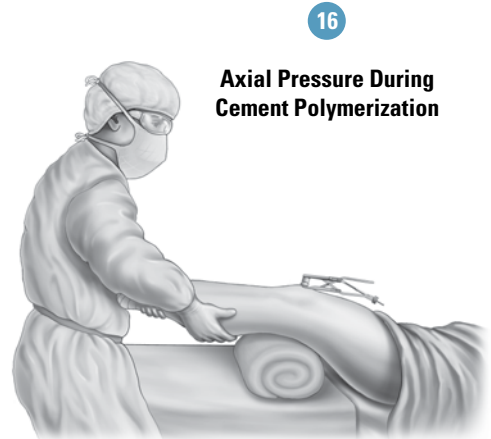

16

Axial Pressure During Cement Polymerization

DETAILED OPERATIVE TECHNIQUE

PRE-OPERATIVE PLANNING

Radiographs

High-quality radiographs are essential for precise pre-operative planning. Films of the full length of the limb will allow the surgeon to determine the mechanical and anatomical axis of the knee more accurately (*Figure 1*).

Templating

Templating is done in both the anterior/posterior and lateral planes to estimate implant size for both the femur and tibia.

APPROACH AND EXPOSURE

The surgeon may use either a straight or medial parapatellar skin incision (*Figure 2*).

The joint is entered through a medial parapatellar incision in the capsule. The incision should be extended proximally in the quadriceps tendon and distally along the medial border of the patellar tendon to the tibial tubercle (*Figure 3*).

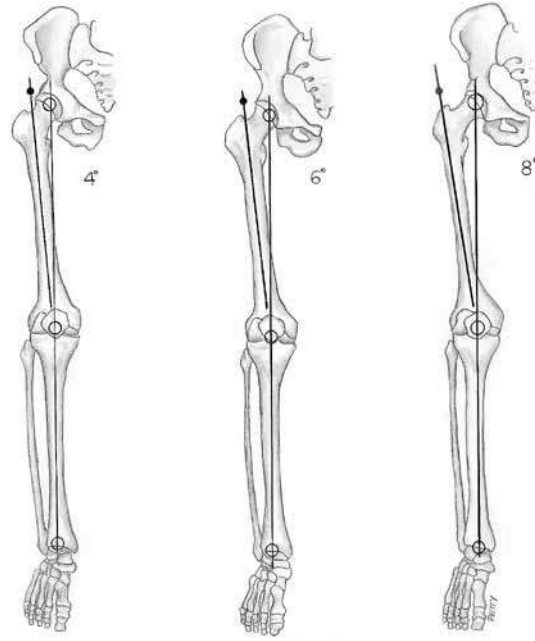

Figure 1

Pre-Operative Full Limb Length Radiographs

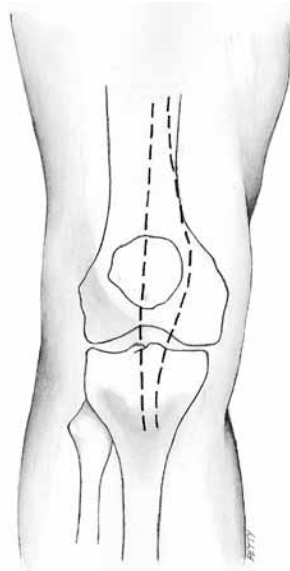

Figure 2

Skin Incisions

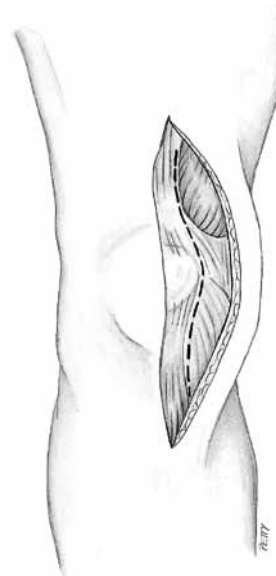

Figure 3

Incision of the Medial Parapatellar Capsule

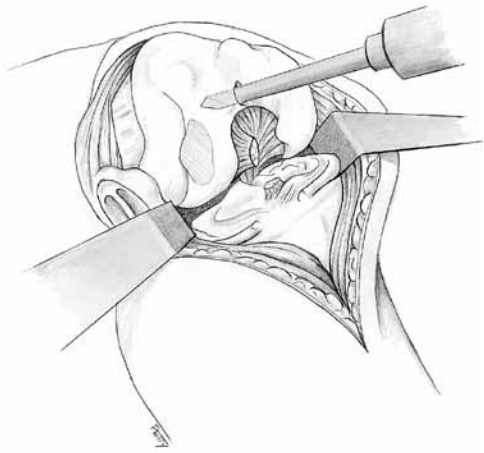

Figure 4
Entry of Intra-medullary Canal
with IM Pilot Drill

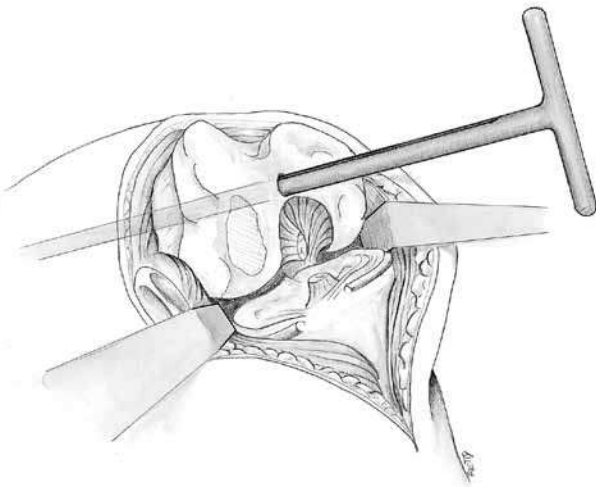

Figure 5
T-Handle IM Rod Placed in Femoral Canal



Figure 6
Setting the Femoral Valgus
Angle

PREPARATION OF THE FEMUR

Step 1: Opening the Intra-medullary Canal

The **Intra-medullary Pilot Drill** should be used to drill a hole in the distal femur coaxially with the femoral endosteal canal (*Figure 4*). The entry point for the IM Pilot Drill is located in the intercondylar groove 5 to 10mm anterior to the intercondylar notch. This entry point may be more accurately located by one of two methods:

1. palpating the femur in the cephalad portion of the exposure or
2. by opening the cortex anterior to the femoral notch with a rongeur, osteotome or gouge. The intra-medullary canal can then be probed with a small curette prior to drilling.

After the canal has been opened with the IM Pilot Drill, the **T-Handle Intra-medullary Rod** should be inserted into the femoral canal to be sure it passes easily. Then, the T-Handle IM Rod should be removed from the canal (*Figure 5*).

Step 2: Femoral Alignment Assembly

The **Intra-medullary Femoral Alignment Guide** should be set for the right or left knee and for the appropriate valgus angle that was determined during pre-operative planning. Typically, this angle is 5, 6 or 7 degrees (*Figure 6*).

Instrument Setup

To set the valgus angle, rotate the distal thumb knob in a counter clockwise direction until the knurled knob rotates freely. Rotate the knurled knob to the proper side (right or left) and the appropriate valgus angle. Tighten the thumb knob.

The IM Alignment Guide is assembled to the T-Handle IM Rod and the T-Handle IM Rod is introduced into the femoral canal (*Figure 7*). The alignment assembly should be brought into contact with the subchondral plate on the distal surface of both femoral condyles. The fixture is then rotated so that its posterior aspect is coplanar with a line drawn across the posterior condyles of the femur. Rotation should be approximately correct, but is not critical in this step (as it will be in Step 5, page 7). The alignment assembly may be pinned to the distal condyles if added stability is desired.

Step 3: Resection of Distal Femoral Bone

The **Distal Femoral Resection Guide** should be placed on the assembly and secured to the femur with headless pins or **1/8-inch Drill Bits** (*Figure 8*). (The Resection Guide may also be placed on the alignment assembly before the assembly is placed in the femur.) The preferred position for the pins is in the holes marked with a "0". This pin position allows the Resection Guide to be relocated in a distal or proximal direction in 2mm increments, in case a more or less aggressive femoral resection is needed. In the neutral ("0") position, 10mm of distal bone is resected. The standard 10mm distal cut established with this instrument system is 2mm greater than the thickness of the femoral component.

Distal femoral bone should be resected using an oscillating saw blade placed through the cutting slots of the Resection Guide (*Figure 9*). A saw blade of the appropriate thickness (.050" or 1.27mm) is crucial to achieving a precise cut in the slotted blocks. If the surgeon prefers to cut the distal femur without using a slot, the same Resection Guide may be used. The open cutting surface of the Resection Guide is 8mm distal to the cutting slot. To establish the appropriate bone resection for cutting on the surface of the Resection Guide, the surgeon should move the Resection Guide 8mm proximally on the IM Alignment Guide before pinning.

Figure 7
IM Alignment Guide
Assembly

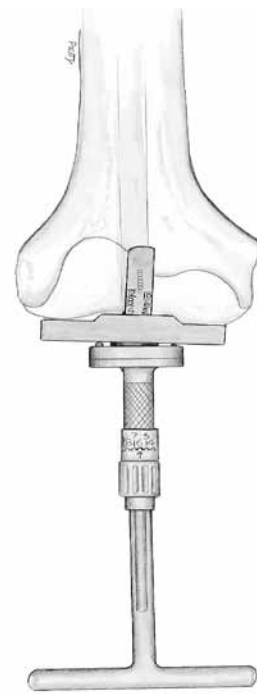

Figure 8
Placement and Pinning of
the Resection Guide

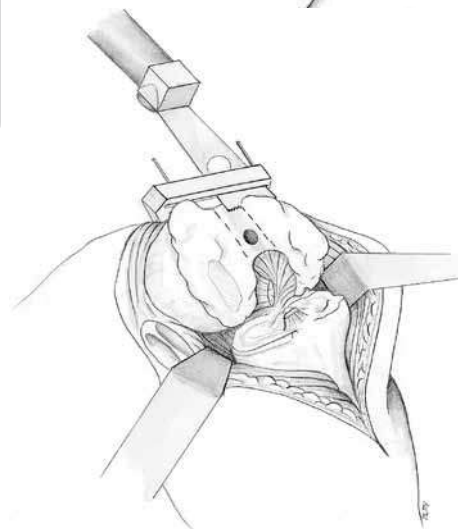
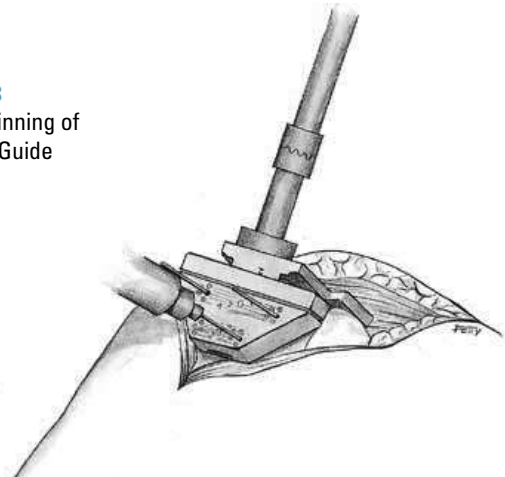

Figure 9
Distal Femoral Cut

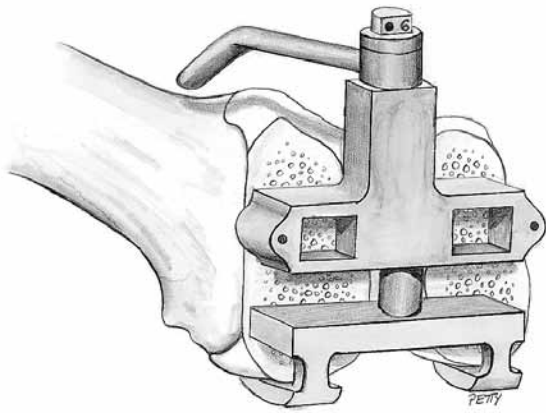

Figure 10
A/P Sizer Placement on Distal Femur

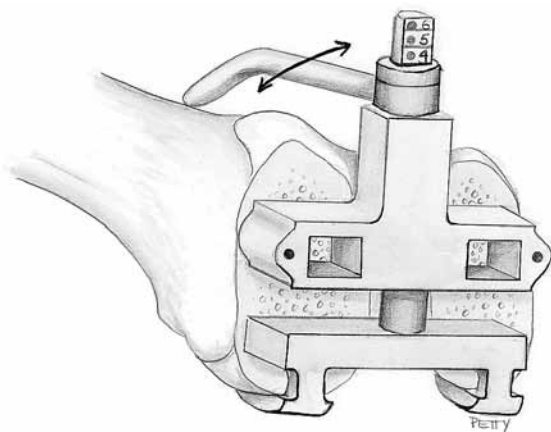

Figure 11
Establishment of Anterior Limit of Femoral Size

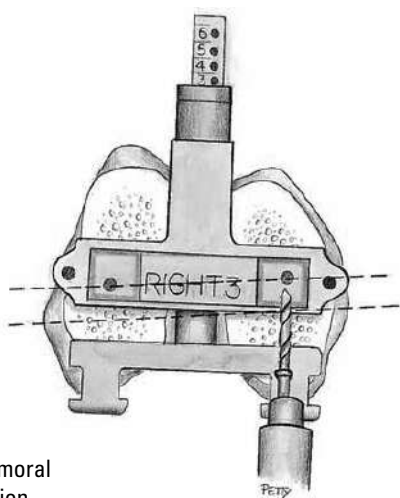

Figure 12
Establish Proper Femoral Component Rotation

To be sure that the resected surfaces of the medial and lateral femoral condyles are flat and coplanar, a flat Resection Guide may be used to check the cuts. If necessary, refinements of the cut may be made.

Recutting the Distal Femur

There are two pin holes in the Resection Guide distal to the cutting slot. If the original pins have been removed and holes cannot be relocated, headed pins can be placed in these holes to relocate the Resection Guide. With the headed pins hanging in the holes, the pins should be placed against the resected distal bone surface. This locates the slot 2mm proximal to the original distal resection. The Resection Guide may then be repinned in the neutral position as before and additional cuts can be made as necessary.

Step 4: Sizing of Femoral Component

The **Femoral A/P Sizer** should be brought flush against the resected surface of the distal femur (*Figure 10*). The posterior feet should then be pulled up against the posterior femoral condyles. If a posterior condylar defect is present, the A/P Sizer should be rotated to a position that accommodates the defect. The A/P Sizer should be placed in the medial/lateral position as though it were a continuation of the femur. The A/P Sizer may be stabilized with pins if the surgeon desires.

A stylus should be placed between the highest and lowest points on the anterior femoral cortex (*Figure 11*). The A/P Sizer should be stabilized by hand. Femoral size may be read from the color-coded scale. If the reading is between sizes, it is usually preferable to choose the smaller size.

Step 5: Establishment of Rotation of Femoral Component

Correct rotation of the femoral component is best established by using the transepicondylar axis as a guide (*Figure 12*). A **0- or 3-Degree Drill Bushing** should be selected for 0 or 3 degrees of external rotation. The right or left Drill Bushing may then be inserted into the A/P Sizer. Two 0.156-inch (4mm) holes are drilled and the A/P Sizer is then removed. The femur is now ready for anterior/posterior and chamfer bone resection.

Step 6: Resection of Anterior, Posterior and Chamfer Femoral Bone

The surgeon should secure the **Femoral Finishing Guide** of the previously determined size to the distal surface of the femur by driving the guide pins into the drilled holes (*Figure 13*). The Femoral Finishing Guide may be further secured by holding it with the removable handles or by placing outrigger pins.

The anterior and posterior femoral surfaces should be resected with an .050" or 1.27mm saw blade (*Figures 14 and 15*). The chamfer cuts should then be made. Femoral preparation is now complete for the posterior cruciate retaining prosthesis. If the posterior stabilized femoral component has been selected, the box cut for this component is described on page 9.

The **Femoral Trial** is now placed (*Figure 16*). Use of a **Locking Femoral Impactor** may help avoid tipping of the prosthesis into flexion. Slight upward pressure on the Impactor handle during impaction will prevent the component from rotating into flexion.

Note: *Non-slotted Resection Guides are available for the anterior/posterior and chamfer cuts for the surgeon who prefers to use these.*

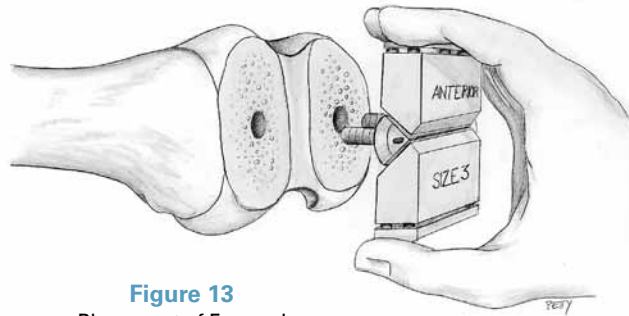

Figure 13
Placement of Femoral Finishing Guide

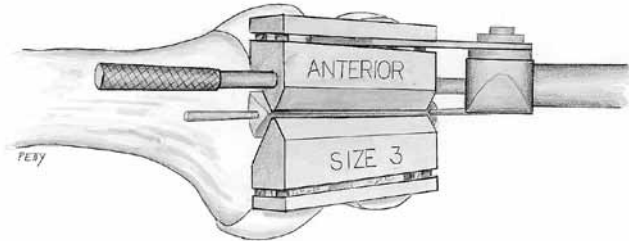

Figure 14
Anterior and Posterior Femoral Resection

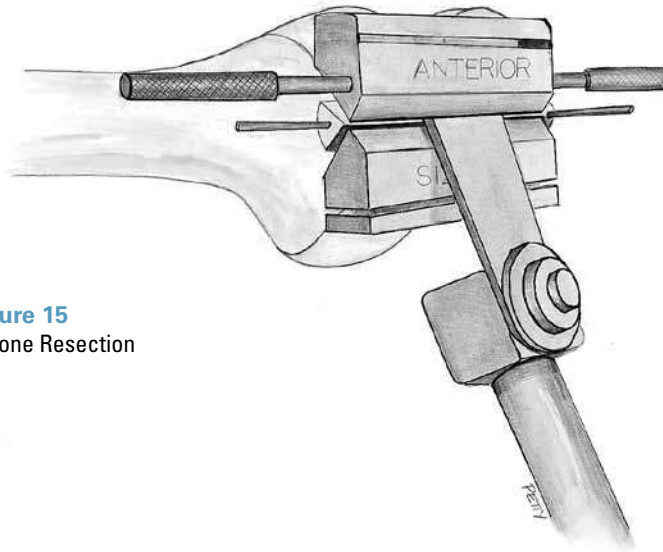

Figure 15
Chamfer Bone Resection

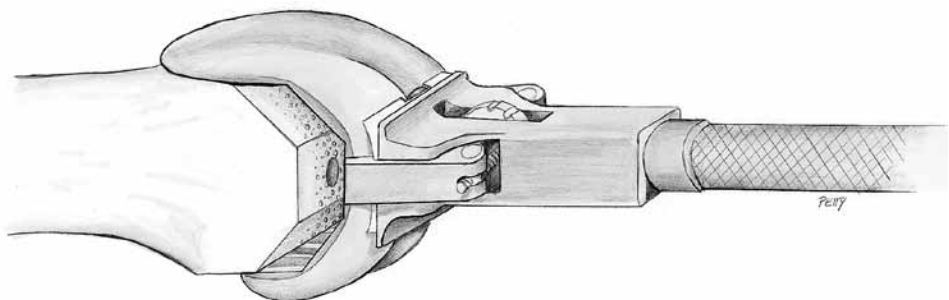

Figure 16
Placement of Femoral Trial

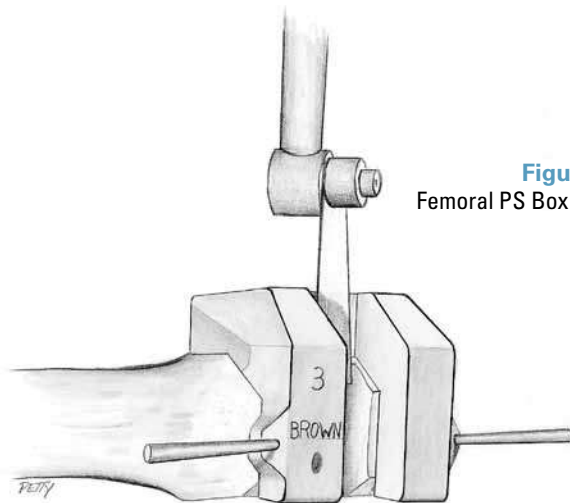

Figure 17
Femoral PS Box Resection Guide

Figure 18
Completed Posterior Stabilized
Femoral Preparation

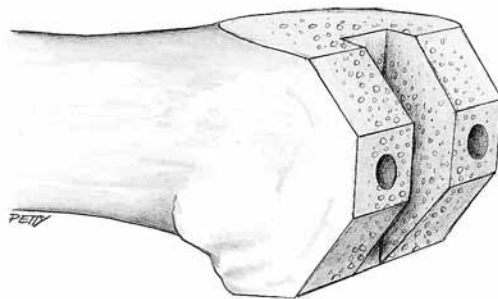
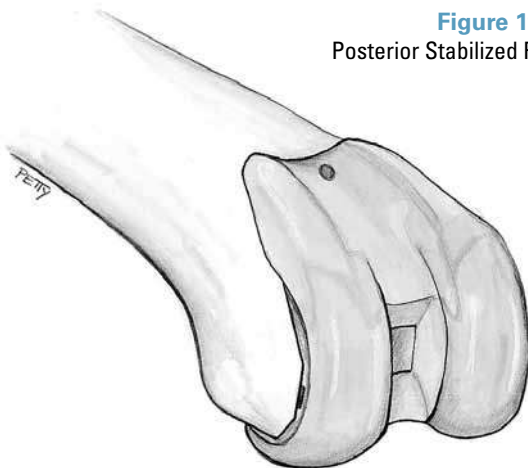

Figure 19
Posterior Stabilized Femoral Trial



POSTERIOR STABILIZED FEMORAL

PREPARATION

After the anterior, posterior and chamfer femoral resections have been completed, the following steps should be taken to prepare the femur for the posterior stabilized femoral component. If the surgeon decides to change to a posterior stabilized prosthesis intra-operatively after all cuts have been made, a similar technique is followed.

The **Femoral PS Box Resection Guide** should be placed on the resected anterior surface of the femur and carefully centered on the condyles (Figure 17). The Box Guide should be held with fixation pins.

An oscillating saw with a narrow blade should be used to make the cuts necessary to accommodate the box of the posterior stabilized femoral implant.

Preparation for the posterior stabilized femoral component is now complete (Figure 18).

The Femoral Trial is placed (Figure 19).

PREPARATION OF THE TIBIA

The surgeon may select either extra-medullary or intra-medullary alignment for placement of the **Slotted Tibial Resection Guide**. The extra-medullary technique will be described first. Description of the intra-medullary technique will follow.

EXTRA-MEDULLARY ALIGNMENT

Step 1: Placement and Distal Alignment of the Extra-medullary Tibial Alignment Guide

Instrument Setup

The Tibial Resection Guide is attached by sliding it onto the dovetail of the **Adjustable Tibial Resector Shaft** and then sliding the Tibial Resector Shaft into the **Tibial Ankle Clamp**. The shaft of the EM Alignment Guide must be rotated 180 degrees within the Tibial Resector in order to slide into position.

The EM Alignment Guide assembly should be placed on the front of the tibia and secured by placing the spring-loaded arms around the ankle in the supramalleolar position (*Figure 20*).

The EM Alignment Guide should be centered over the ankle joint (*Figure 21*). This center is located in the depression between the extensor hallucis longus and the extensor digitorum longus tendons. The EM Alignment Guide may be adjusted by loosening the anterior knob on the Ankle Clamp. In most instances, the EM Alignment Guide will read 2 to 5mm medial to "0" when properly centered.

In the sagittal plane, the Tibial Resector Shaft should be aligned parallel to a line extending from the center of the knee joint to the center of the ankle joint (*Figure 22*). If the surgeon prefers, a posterior tilt may be added at this point by sliding the vertical bar slightly more anteriorly (*Figure 25*).

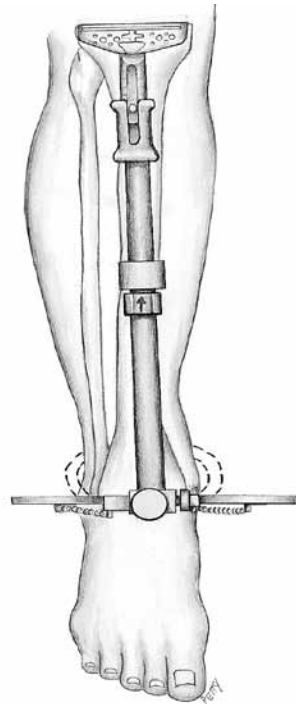

Figure 20
Placement of EM Alignment Guide

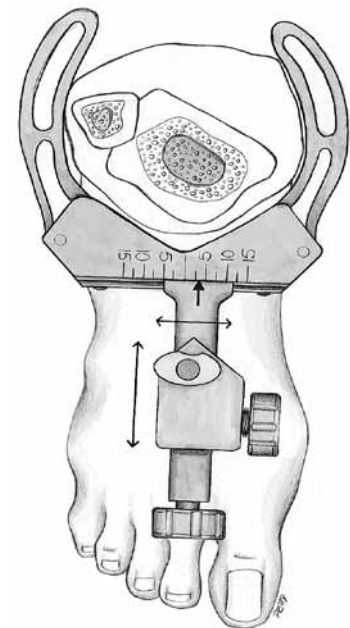

Figure 21
Setting Medial/Lateral Alignment at Ankle

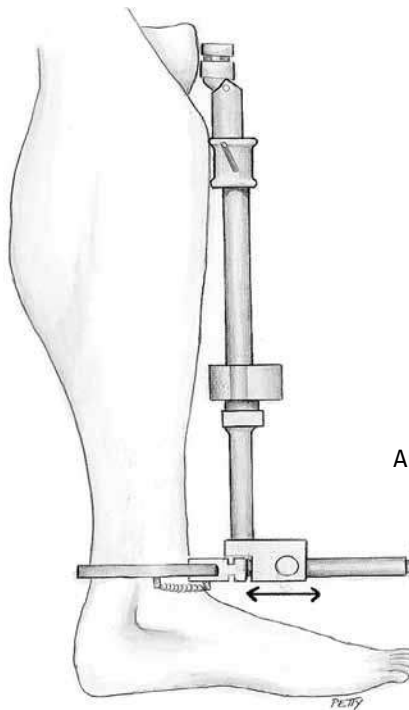

Figure 22
Anterior/Posterior Tibial Alignment

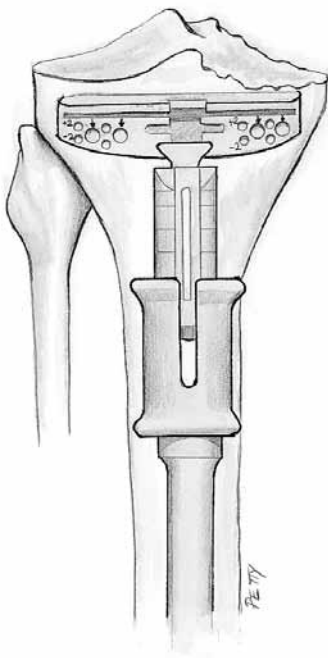

Figure 23
Proximal Alignment of EM
Alignment Guide in Frontal Plane

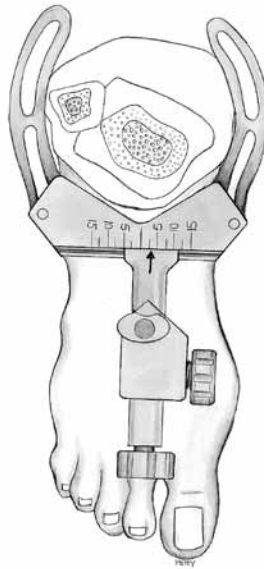

Figure 24
Rotational Alignment

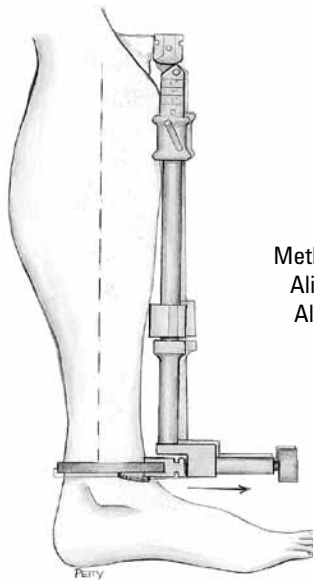

Figure 25
Method 1: Anterior/Posterior
Alignment by Angling EM
Alignment Rod to Create
Posterior Tilt

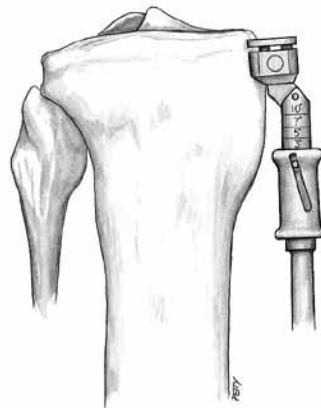

Figure 26
Method 2: Anterior/Posterior
Alignment Using Cam on EM
Alignment Guide

Step 2: Proximal Alignment

In the frontal plane, the Tibial Resector Shaft should be aligned with the long axis of the tibia (*Figure 23*). Normally, this may be accomplished by centering the vertical **Extra-medullary Alignment Rod** on the center of the tibial plateau.

The EM Alignment Guide should be set rotationally by aligning it with the second toe or, if there is an ankle or foot deformity, by pointing it in the same direction that the tibial tubercle points (*Figure 24*).

The posterior slope present in the individual tibia should, in most cases, be reproduced in the proximal tibial resection. In most tibia, this is a 3- to 5-degree angle. The surgeon may choose one of two methods for establishing the posterior slope of the proximal tibia.

Method 1: The Tibial Resector Shaft should be set so that it is parallel with the long axis of the tibia in the anterior/posterior plane (*Figure 25*). The posterior slope may then be set by leaving the cam adjustment on "0" and adjusting the EM Alignment Rod more anteriorly at the ankle. To make this adjustment, loosen the thumb screw on the side of the Ankle Clamp, set the alignment in the desired position and tighten the thumb screw.

Method 2: The Tibial Resector Shaft should be placed parallel to the long axis of the tibia (*Figure 26*). The posterior slope should be set by dialing the selected degree of slope with the cam adjustment. This slope angle is normally 3 to 5 degrees.

Step 3: Determination of Tibial Resection Depth

The Tibial Resection Guide should be placed on the dovetail of the EM Alignment Guide if the guide was not pre-assembled. The **Fixed Tibial Stylus** should be placed in the cutting slot of the EM Alignment Guide so that either the side marked "most normal" or the side marked "most defective" extends over the tibial plateau.

If the surgeon chooses to measure depth resection from the most normal tibial plateau, the end of the Fixed Tibial Stylus marked "most normal" should be placed on the center of the most normal plateau (Figure 27). This level provides for 10mm of bone resection.

If depth resection is measured from the more defective plateau, the end of the Fixed Tibial Stylus marked "most defective" should be placed on the defective tibial plateau (Figure 28). The level of bone resection is 1mm below the defective area of plateau on which the Fixed Tibial Stylus rests.

Step 4: Securing Tibial Resection Guide to Tibia and Final Checking

When the proper positioning of the Tibial Resection Guide has been assured, drill pins should be placed through the Tibial Resection Guide into the tibia (Figure 29). After the drill holes marked with arrows have been selected, the surgeon may make a 10mm resection from the most normal side of the tibial plateau or a 1mm resection from the most defective side of the tibial plateau. The Tibial Resection Guide may be adjusted proximally or distally in 2mm increments to either decrease or increase the tibial resection. If the surgeon prefers to resect from the top of the Tibial Resection Guide, the surface cut will be 4mm more proximal than a cut through the slot.

The EM Alignment Guide may be removed by first opening the Ankle Clamp, then sliding the EM Alignment Guide forward off the Tibial Resection Guide (Figure 30).

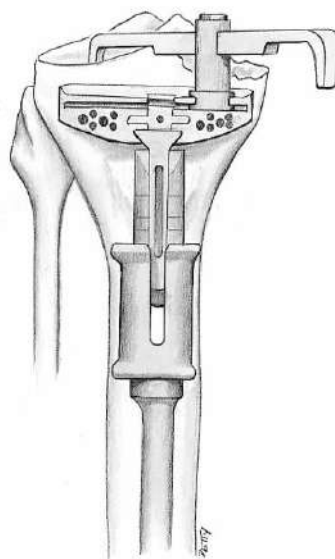

Figure 27
Tibial Depth Resection Measured from "Most Normal" Tibial Plateau

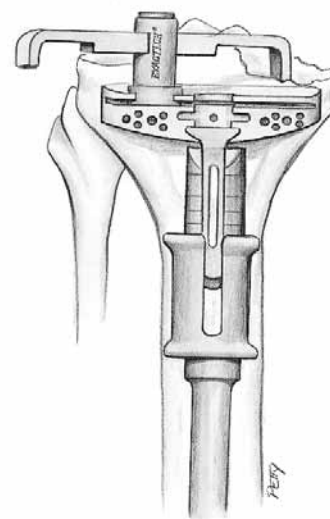

Figure 28
Tibial Depth Resection Measured from "Most Defective" Tibial Plateau

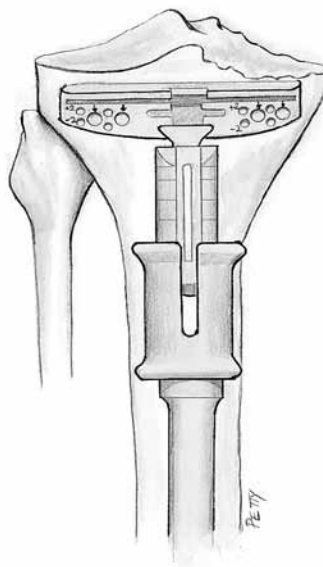

Figure 29
Securing Tibial Resection Guide to Tibia

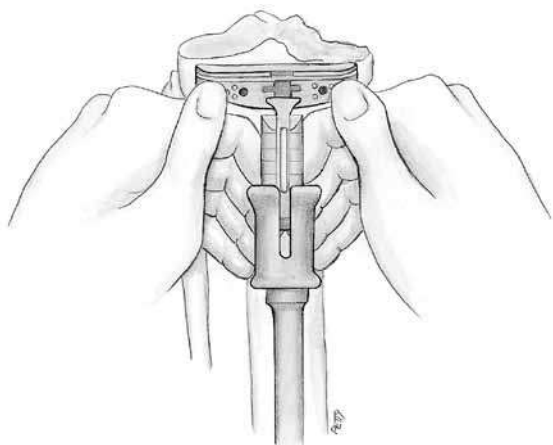

Figure 30
Removal of EM Alignment Guide

Figure 31
Final Alignment Check

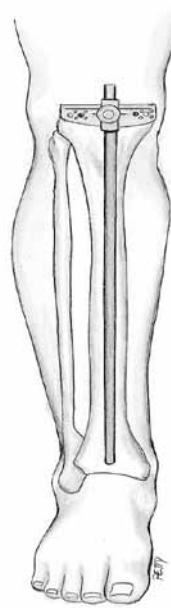

Figure 32
Locating Entry Point for
IM Pilot Drill

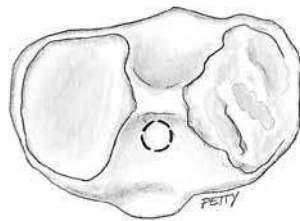
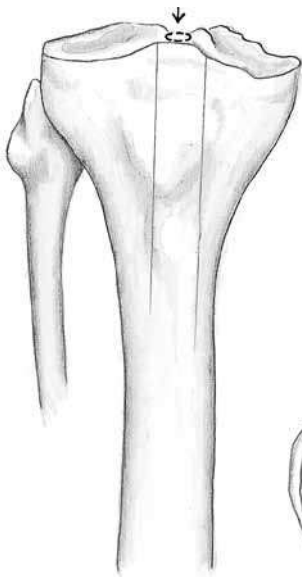
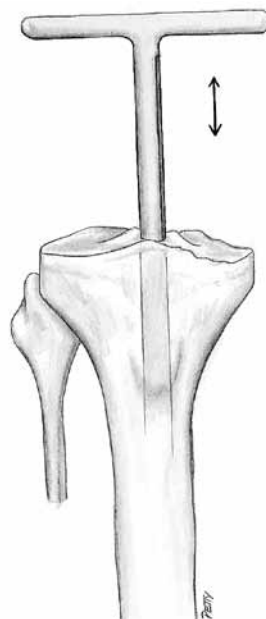

Figure 33
T-Handle IM Rod in
Tibial Canal



The surgeon should make a final check for proper alignment by securing the **Mauldin Multi-Tool** to the Tibial Resection Guide and placing an EM Alignment Rod through one of the holes in the handle (*Figure 31*). Alignment can also be checked by placing the T-Handle IM Rod over the drill points that secure the proximal Tibial Resection Guide. This T-Handle IM Rod may be allowed to dangle from the drill points. Assuming the T-Handle IM Rod lies proximally in the sagittal midline of the proximal tibial plateau, the distal tip of the bar should lie over the center of the ankle joint. The EM Alignment Rod in the handle shows alignment in both planes while the T-Handle IM Rod shows alignment in only the frontal plane.

INTRA-MEDULLARY ALIGNMENT

Step 1: Opening of the Intra-medullary Canal

The IM Pilot Drill is used to drill a hole in the proximal tibia coaxially with the tibial endosteal canal (*Figure 32*). The entry point for the IM Pilot Drill is most accurately located by finding the proximal extension of the center of the intra-medullary canal on the pre-operative X-ray films. This point often lies between the tibial spines in the frontal plane and just anterior to them in the sagittal plane.

The surgeon may use an awl, rongeur, osteotome or gouge to help open the entry point for the IM Pilot Drill. The intra-medullary canal may then be probed with a small curette prior to drilling. The canal is then entered with the IM Pilot Drill.

After opening the canal with the IM Pilot Drill, the surgeon should insert the T-Handle IM Rod into the tibial canal to be sure it passes easily (*Figure 33*). Then the T-Handle IM Rod should be removed from the canal.

Step 2: Assembly and Placement of IM Alignment Guide

Instrument Setup

Slide the Tibial Resection Guide onto the anterior dovetail of the IM Alignment Guide and tighten the anterior knurled knob. Rotate the superior knob clockwise until the resection head is in its highest position. Assure that the varus/valgus adjustment is set at "0". Rotate the slope-selection knob to the desired position. Loosen the rod-locking knob and slide the T-Handle IM Rod into the IM Alignment Guide.

The T-Handle IM Rod should be inserted into the IM Alignment Guide and again inserted into the tibial intra-medullary canal (*Figure 34*).

Step 3: Guide Alignment and Stabilization

The IM Alignment Guide should be aligned rotationally by aligning it with the second toe or, if there is a foot or ankle deformity, by pointing it in the same direction as the tibial tubercle points.

After rotational alignment has been set, the flutes of the IM Alignment Guide should be slightly tapped into the tibial plateau to stabilize the IM Alignment Guide (*Figure 35*).

To be sure that varus/valgus alignment is correct, the surgeon should place an EM Alignment Rod in the anterior hole of the IM Alignment Guide (*Figure 36*). The EM Alignment Rod should be aligned with the center of the ankle joint. This center lies in the depression between the extensor hallucis longus and extensor digitorum longus tendons at the ankle.

The posterior slope should be adjusted by dialing the appropriate degrees on the posterior slope adjustment knob (*Figure 37*). The EM Alignment Rod will show the slope compared with the sagittal plane of the intra-medullary canal of the tibia.

Step 4: Determination of Tibial Resection Depth

The Tibial Resection Guide should be placed on the dovetail of the IM Alignment Guide if the Resection Guide was not pre-assembled. The Fixed Tibial Stylus should be placed in the cutting slot of the Resection Guide with either the side marked "most normal" or "most defective" extending over the tibial plateau. Depth resection should be set using the adjustment knob near the top of the IM Alignment Guide.

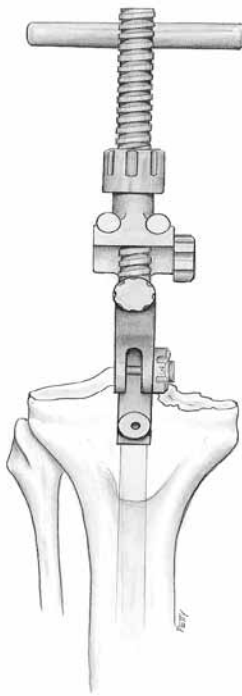

Figure 34
Placement of IM Alignment Guide into Tibia

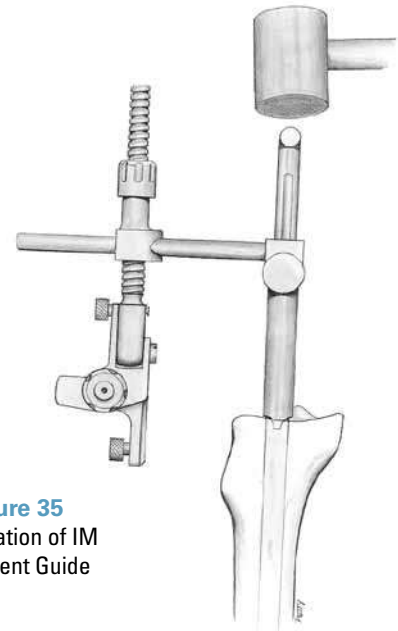

Figure 35
Stabilization of IM Alignment Guide

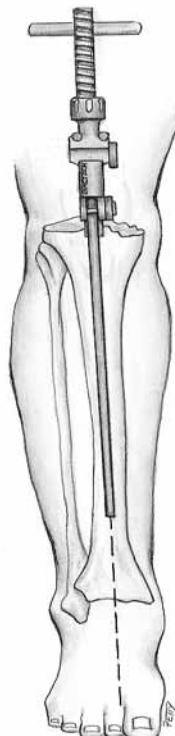

Figure 36
Varus/Valgus Alignment

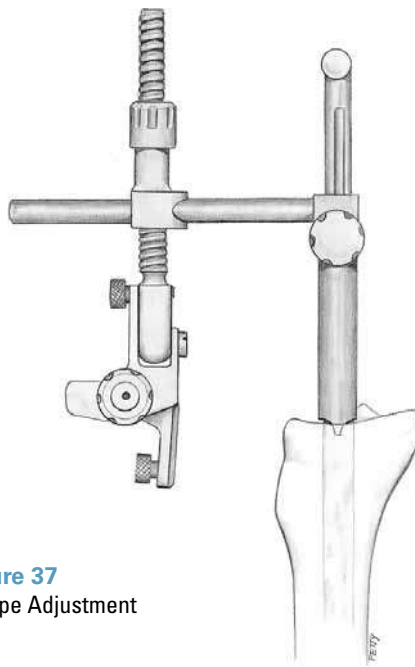

Figure 37
Posterior Slope Adjustment

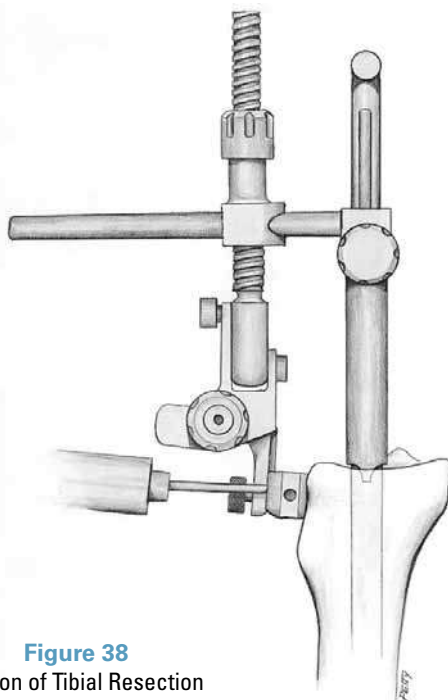

Figure 38
Fixation of Tibial Resection
Guide to Tibia

If the surgeon chooses to measure depth resection from the most normal tibial plateau, the “most normal” end of the Fixed Tibial Stylus should be placed on the center of the most normal plateau. This level provides for 10mm of bone resection.

Note: See page 12, Figure 27.

If depth resection is measured from the more defective plateau, the side of the Fixed Tibial Stylus marked “most defective” should be placed on the defective tibial plateau. The level of bone resection is 1mm below the defective area of plateau on which the Fixed Tibial Stylus rests.

Note: See page 12, Figure 28.

Step 5: Pinning of Tibial Resection Guide, Removal of IM Alignment Guide and Final Checking

When the proper positioning of the Tibial Resection Guide has been assured, drill pins are placed through the Tibial Resection Guide into the tibia through the holes marked with an arrow (Figure 38). After the drill holes marked with arrows have been selected, 10mm resection may be accomplished from the end of the Fixed Tibial Stylus marked “most normal” or 1mm from the end of the Fixed Tibial Stylus marked “most defective”. The amount of tibia resected may be decreased or increased by proximal or distal adjustment of the Tibial Resection Guide in 2mm increments.

If the surgeon prefers to resect from the top of the guide, the surface cut will be 4mm more proximal than a cut through the slot.

To remove the IM Alignment Guide, the knob which holds the guide on the T-Handle IM Rod should be loosened and the T-Handle IM Rod should be removed. The IM Alignment Guide and T-Handle IM Rod should be removed together as the end of the T-Handle IM Rod is loosened in the intra-medullary canal. An extractor hook and slap hammer are available to aid in removing the T-Handle IM Rod and IM Alignment Guide if necessary. Alternatively, both the T-Handle IM Rod and the IM Alignment Guide may be tapped lightly with a mallet to remove.

A final check for proper alignment should be performed by securing the Mauldin Multi-Tool to the Tibial Resection Guide and placing an EM Alignment Rod through one of the holes in the handle (Figure 39). Alignment may also be checked by placing the T-Handle IM Rod over the drill points that secure the proximal Tibial Resection Guide. This T-Handle IM Rod may be allowed to dangle from the drill points and, assuming that the T-Handle IM Rod lies proximally in the sagittal midline of the proximal tibial plateau, the distal tip of the bar should lie over the center of the ankle joint.

The EM Alignment Rod in the handle shows alignment in both planes while the T-Handle IM Rod shows alignment in only the frontal plane.

Step 6: Proximal Tibial Bone Resection

Bone resection should be performed by cutting through the slot of the Tibial Resection Guide with an oscillating saw (Figure 40). (If the surgeon chooses to cut on the upper surface of the Tibial Resection Guide, 4mm less bone will be resected so the appropriate adjustment should be made). The surgeon should take care during the tibial resection to avoid injury to the collateral structures and the posterior neural and vascular structures. The tibial attachment of the posterior cruciate ligament should be saved when cruciate retaining prostheses are to be used.

The cut tibial surface should be sized using the Tibial Tray Trials (Figure 41). For a given size of femoral component, the surgeon has a choice of three Tibial Tray Trial sizes: these include the same nominal size as the femoral component, one size larger and one size smaller. This system provides for a tibial articular surface that is precision-matched for its mating femoral component; this results in the low articular stresses seen with the Optetrak prosthesis. The Tibial Tray Trials have a color code that matches the femoral trial component. The surgeon should choose the largest Tibial Tray Trial that fits within the borders of the resected tibial surface, without any overhang.

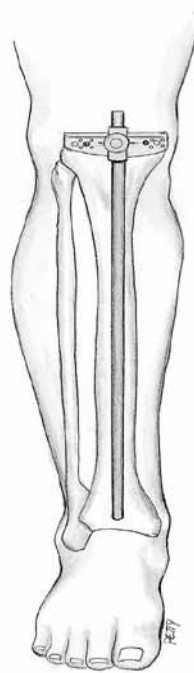

Figure 39
Final Alignment Check

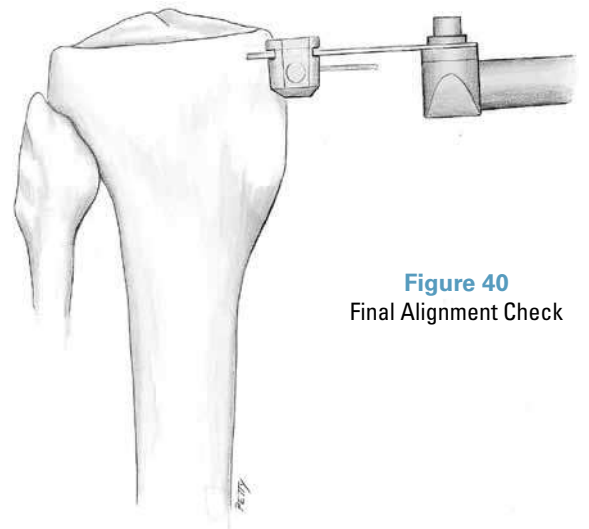

Figure 40
Final Alignment Check

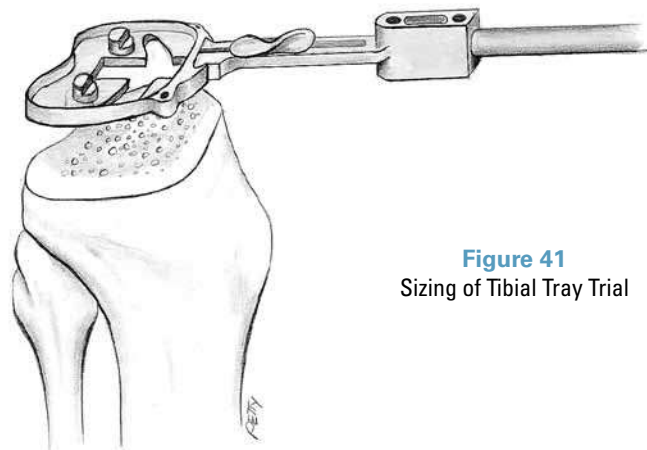

Figure 41
Sizing of Tibial Tray Trial

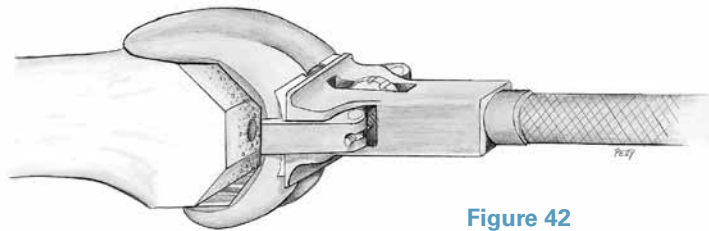

Figure 42
Placement of Femoral Trial

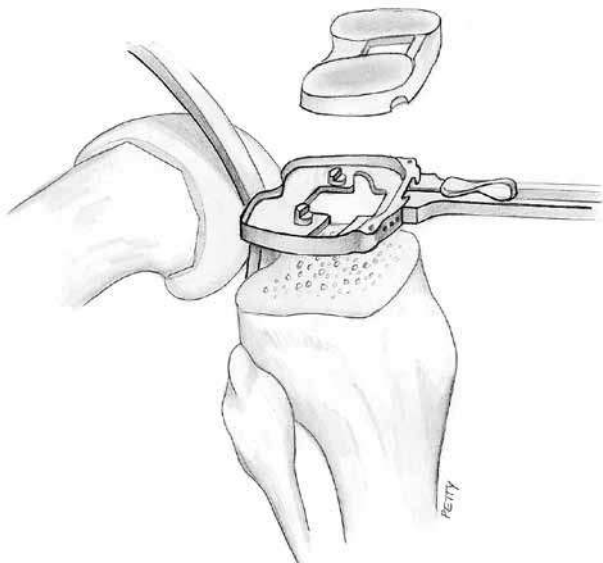

Figure 43
Selection of Proper Tibial Insert Trial

PLACEMENT AND SIZING OF TRIAL COMPONENTS

The Femoral Trial is placed with the Locking Femoral Impactor or by hand (*Figure 42*). If placed by hand, it is helpful to pull proximally on the component with a bone hook in the intercondylar notch to assure the component goes straight on the prepared bone surfaces, avoiding the tendency that femoral components sometimes exhibit of rotating slightly into flexion. Ensure that the component is centered on the condyles in the medial/lateral direction. When correct positioning is assured, the component is fully seated with the Femoral Impactor and a mallet.

The size, number and color of the **Modular Tibial Insert Trial** matches that of the size, number and color dot on the Femoral Trial (*Figure 43*). The surgeon should assess the different thicknesses of Tibial Insert Trials, usually beginning with the 9mm Tibial Insert Trial. The correct selection is the insert that allows for full extension and slight laxity (similar to that of a typical normal knee) in both extension and flexion. The range of motion may be checked at this stage, but the final check for kinematics is best completed after patellar preparation.

PREPARATION OF THE PATELLA

Step 1: Resection of the Patellar Articular Surface

The articular surface of the patella may be resected with or without the use of the **Slotted Patellar Resection Guide**, depending on the surgeon's preference. Resection may be done with the knee either flexed or extended.

Method 1: Free-Hand Resection

For patellar resection performed without the Patellar Resection Guide ("free hand"), the patella should be stabilized with large towel clips or similar instruments (*Figure 44*). Either of two landmarks should be used:

1. from edge of medial articular surface to edge of lateral articular surface or
2. beginning just posterior to the patellar tendon origin at the inferior pole of the patella and cutting superiorly, parallel to the plane of the patella. The posterior patellar surface should be resected with an oscillating saw.

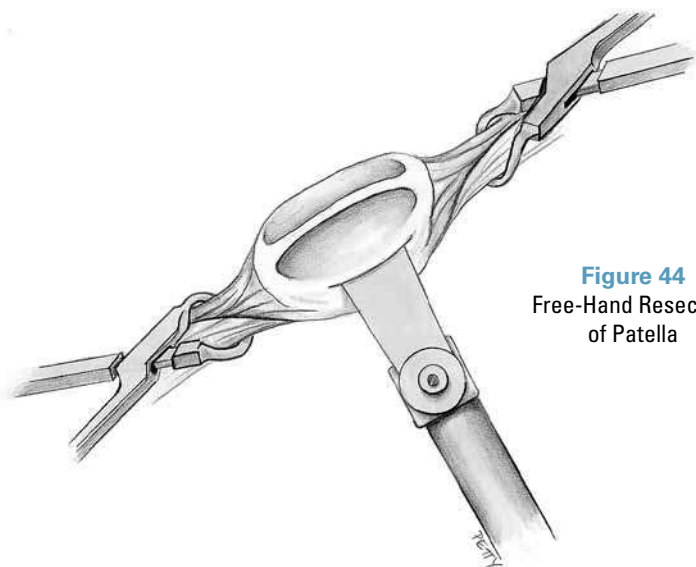

Figure 44
Free-Hand Resection of Patella

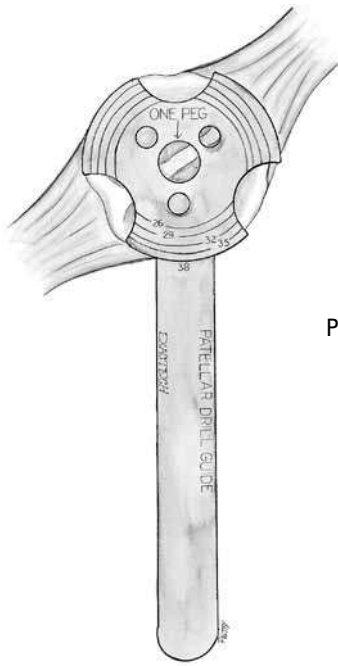

Figure 45
Patellar Sizing

TABLE 1
Relationship of Patellar Prosthesis
Diameter to Thickness

Diameter (mm)	Thickness (mm)
26	5.1
29	6.1
32	7.2
35	8.5
38	10.0
41	11.1

Method 2: Using the Patellar Resection Guide

The Patellar Resection Guide for the Opttrak Knee System provides accurate measurement of patellar thickness and the amount of bone resected so that the amount of patella remaining after resection is easily calculated.

The thickness of the patellar prosthesis increases with increasing diameter—just as it does with the normal patella and most other total knee systems (*Figure 45*). Patellar diameter may be determined by placing the **Patellar Drill Guide** over the patella. Osteophytes must be removed prior to this measurement to assure accuracy.

Resection depth of the patella is based on the estimated patellar diameter measured (*Table 1*).

The Patellar Resection Guide consists of a **Patellar Cement Clamp** combined with a measuring device and saw guide (*Figure 46*). The Patellar Cement Clamp should be positioned with the saw guide ring circumferentially placed on the patella. Care should be taken not to squeeze the handles too tightly during sawing to avoid displacing the Resection Guide surface location. The Resection Guide may be held in the center (at the pivot position) to maintain the Resection Guide's stability and position.

After the Patellar Cement Clamp is placed around the patella and tightened, the clamp adjustment knob should be turned to lock the Patellar Cement Clamp. Patellar thickness should be read from the "Patellar Thickness" gauge.

Figure 46
Placement of Patellar Resection Guide
and Measurement of Patella

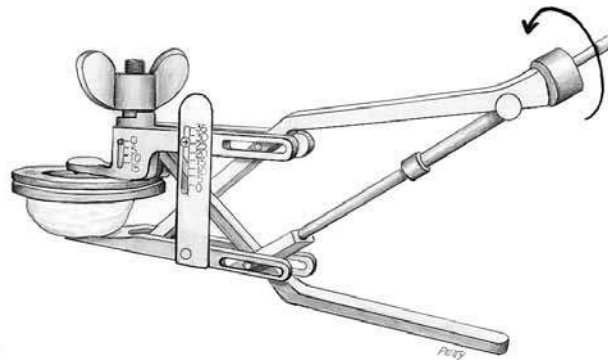
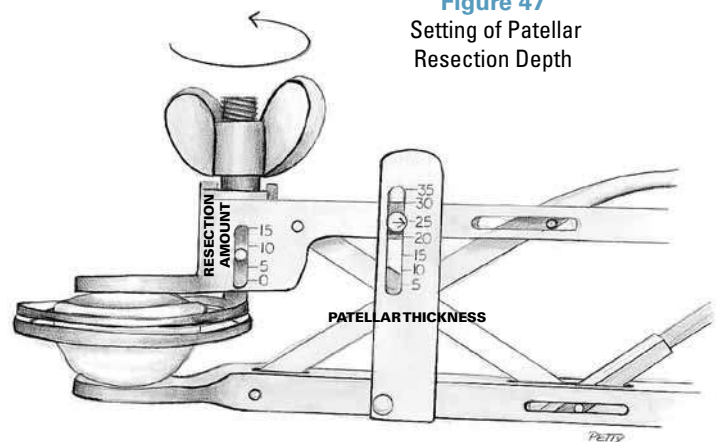

Figure 47
Setting of Patellar
Resection Depth



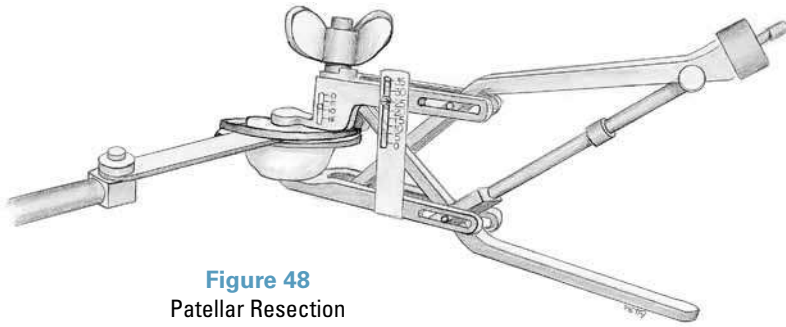

Figure 48
Patellar Resection

The “wing-nut” knob for resection depth adjustment should be turned to the desired resection depth (*Figure 47*). If the surgeon prefers to resect the amount of bone which will be replaced by a specific diameter patellar component, the thicknesses are listed in Table 1. After the resection depth is selected, the patella is ready for resection.

The patellar surface should be resected with an oscillating saw (*Figure 48*). The saw blade should be placed through the cutting slot of the saw guide ring for resection.

Step 2: Final Sizing and Drilling of Patella

When patellar resection is complete, final determination of size and hole preparation should be performed using the Patellar Drill Guide (*Figure 49*). The Drill Guide should be placed on the resected patellar surface, providing a size check for all sizes of the patella. It also provides guide holes for the drill for three-peg or single-peg prostheses.

Holes should be drilled through the Patellar Drill Guide in either the three-hole or single-hole configuration (*Figures 50 and 51*).

Step 3: Patellar Trial Placement

The appropriate size of the **Three-Peg Patella Trial** should be placed on the patella.

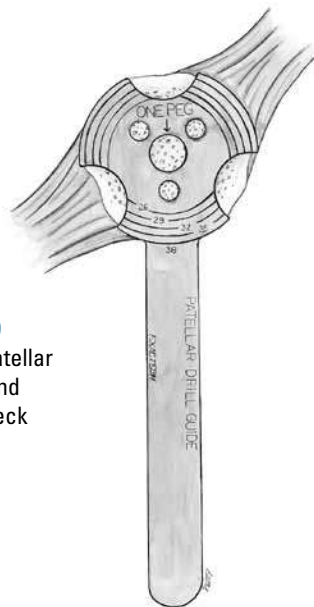

Figure 49
Placement of Patellar
Drill Guide and
Final Size Check

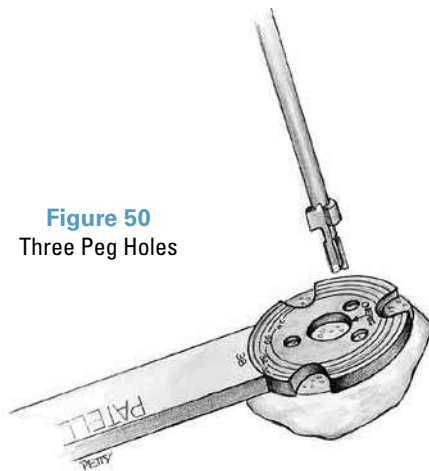

Figure 50
Three Peg Holes

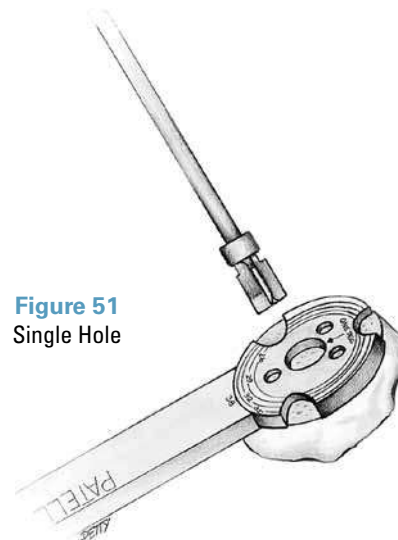

Figure 51
Single Hole

FINAL PROSTHESIS TRIAL CHECK

Final prosthesis trial check should include assessment of:

ALIGNMENT,
STABILITY,
MOTION and
PATELLAR TRACKING

Alignment Check

With the knee in full extension and the Mauldin Multi-Tool assembled to the Tibial Base Plate, EM Alignment Rods should be placed in the holes in the Mauldin Multi-Tool and the alignment should be assessed (*Figure 52*). Proper rotation of the tibial component should be determined by its congruency with the femoral component. Normally, the anterior plane of the tibial component will point approximately in the direction of the tibial tubercle and second toe when congruency is established. When proper alignment is achieved, the Alignment Rods will be centered over the ankle and estimated location of the center of rotation of the femoral head.

Stability Check

The knee should be assessed for stability in both extension and flexion (*Figures 53 and 54*). The extension check should be performed with the knee flexed a few degrees to relax the posterior capsule. However, the knee should extend fully. The flexion check should be performed with the knee flexed to 90 degrees. The most appropriate stability is achieved when the medial and lateral opening is similar to that of a normal knee during application of valgus and varus stress. An adjustment of ligament balance may be needed, if there is differential ligament tightness between varus and valgus in flexion or extension.

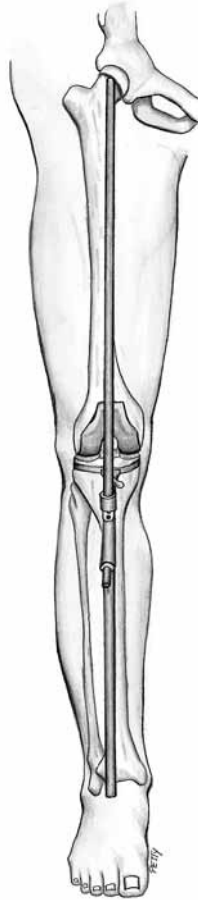

Figure 52
Assessment of Alignment

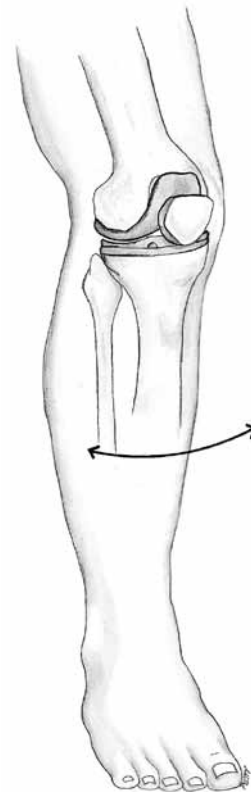

Figure 53
Stability Check in
Extension



Figure 54
Stability Check in Flexion

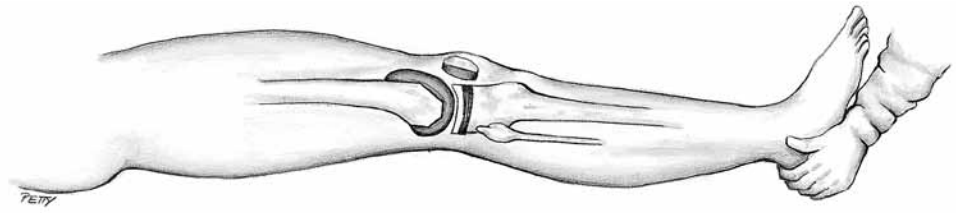

Figure 55
Extension Check



Figure 56
Flexion Check

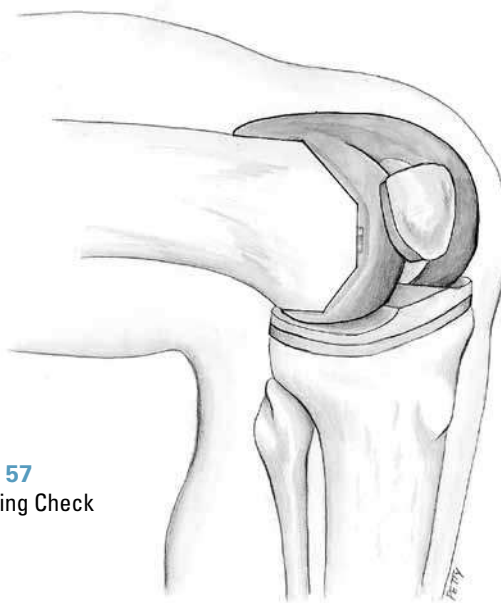

Figure 57
Patellar Tracking Check

Motion Check

The knee should extend fully without force (*Figures 55 and 56*). To check flexion, the surgeon should elevate the thigh and allow the leg to flex by the pull of gravity. The amount of flexion determined in this manner is the best intra-operative predictor of the flexion that will ultimately be achieved.

Patellar Tracking Check

As the knee is put through a range of motion, the patella should track smoothly in the patellar groove of the femoral prosthesis with little or no pressure exerted against its lateral edge and without it being held medially (*Figure 57*). If there is a tendency to lateral subluxation, lateral retinacular release should be performed. Because of the system's advanced patellar groove and condylar design, lateral retinacular release is unlikely to be needed as often as it is with most other knee systems.

FINAL BONE PREPARATION: FEMUR

Femoral Peg Hole Preparation

When all checks are completed, holes may be drilled for the pegs of the cruciate-retaining femoral component (*Figure 58*). If the surgeon prefers a tighter fit for the pegs and less cement intrusion into the holes, a small punch may be used to create these holes. Alternatively, if the small holes created for the Femoral Finishing Guide are in the correct medial/lateral location, they may be used for the pegs of the cruciate retaining femoral prosthesis. (This step is not necessary for the posterior stabilized femoral component.)

FINAL BONE PREPARATION: TIBIA

Step 1: Fixation of Tibial Tray Trial

When all checks have been completed, pins may be drilled or driven into the medial and lateral outrigger holes on the Tibial Tray Trial (*Figure 59*). Sometimes it is difficult to place the lateral pin in patients with a large or tight patellar tendon until the knee is flexed and the Femoral Trial prosthesis and Tibial Insert Trial are removed. If this is the case, the surgeon should place the medial pin, hold the proper rotation of the Tibial Tray Trial while these other trial components are removed, and then place the lateral pin. Once the Tibial Tray Trial insert is removed, the surgeon will have access to additional pin fixation holes in the bottom of the Tibial Tray Trial, should these be needed. At this point, the Patellar Trial prosthesis should be removed.

Step 2: Drilling the Central Cavity

The **Tibial Pilot Drill Guide** should be assembled to the Tibial Tray Trial and the IM Pilot Drill should be drilled to the depth that matches the Tibial Tray Trial size (*Figure 60*).

Step 3: Tamping for Tibial Stem

Whether the **Net-shape Tibial Finned Tamp** or **Trapezoid Tibial Tamp** is used, the same technique for preparation is followed. The different shapes are created by selecting the appropriate shape of Tamp.

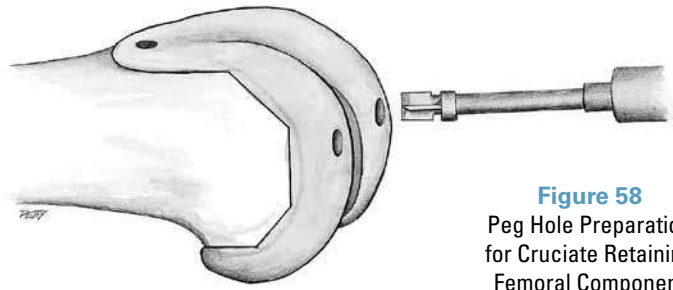

Figure 58
Peg Hole Preparation
for Cruciate Retaining
Femoral Component

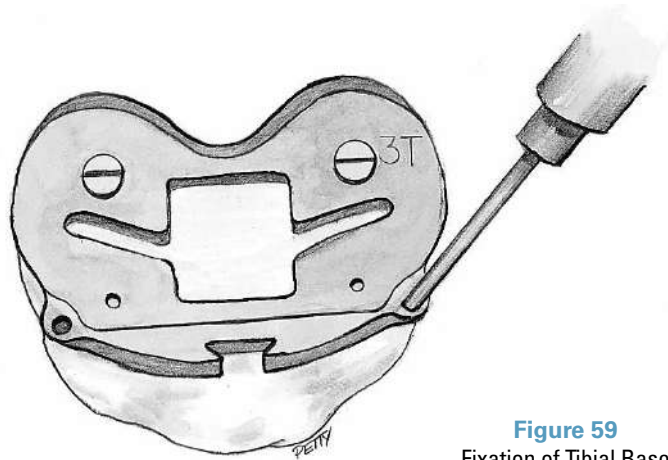

Figure 59
Fixation of Tibial Base
Plate Trial

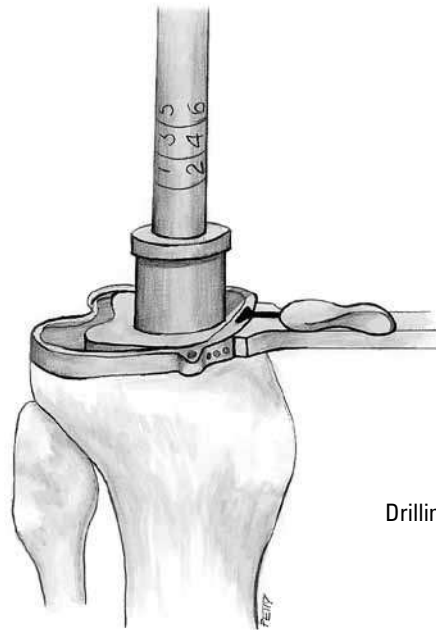

Figure 60
Drilling Central Cavity

Figure 61
Tibial Tamp Assembly and Setting of
Tamp for Selected Tray Size

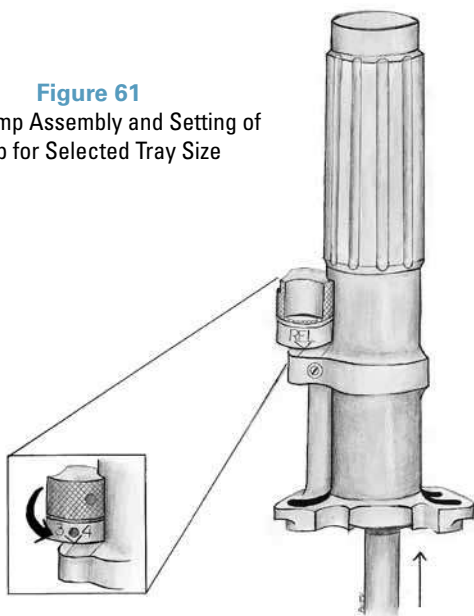
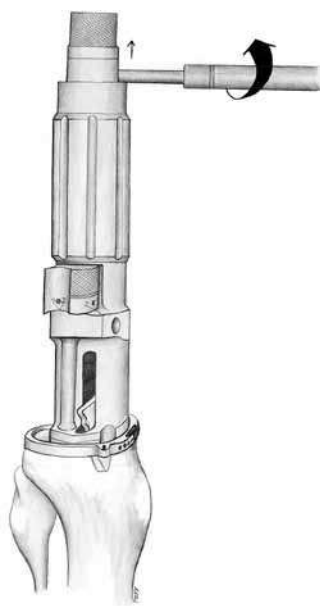

Figure 62
Tamping Tibia for
Tibial Stem

Figure 63
Removal of Tibial Tamp



The selected Tamp is assembled to the **Tibial Tamp Guide** by dialing REL (release) on the tray-size adjustment knob (*Figure 61*). Then, the Tamp is inserted into the Tamp Guide. After assembly, the Tamp Guide should be set for the Tibial Tray Trial size being used by dialing the proper number on the Tibial Tray Trial size adjustment knob. This accomplishes three things:

1. secures the Tamp to the Tamp Guide;
2. assures proper bone penetration for the Tamp; and
3. sets the Tamp Guide so that it will seat properly on the Tibial Base Plate Trial. If the correct size is not set for the tray being used, the Tamp Guide will not seat properly on the Tibial Tray Trial. This is a safety check to be certain tamping is correct for the selected Tibial Tray Trial.

The Tamp Guide should be seated on the Tibial Tray Trial and the Tamp driven into the tibia until the stop is reached (*Figure 62*). The appropriate size is marked by a line at the top of the Tamp Guide; this serves as an additional check to indicate when the Tamp is fully seated.

The Tamp should be removed by inserting the small stud on the end of the Mauldin Multi-Tool into the hole in the handle of the Tibial Tamp, then rotating the Mauldin Multi-Tool to loosen the Tibial Tamp (*Figure 63*). If needed, a threaded hole is available for attachment of a slap hammer to remove the Tamp. However, it is usually easily removed after loosening with the Mauldin Multi-Tool. The Tamp and Tamp Guide may be removed. At this point, the fixation pins and Tibial Base Plate Trial should be removed. Next, the prostheses will be implanted.

PROSTHESIS IMPLANTATION

Surgeons have different preferences in regard to the sequences used to place the prosthesis components. A standard, successful technique sequence is described here. If the surgeon prefers another sequence, the Optetrak Knee System provides sufficient flexibility to accommodate adjustments in the implantation technique.

Step 1: Final Bone Preparation

Retractors should be placed to expose the proximal tibia (Figure 64).

All tissue debris should be removed from resected bone surfaces. The bone trabeculae should be thoroughly cleansed with pulsed lavage.

Step 2: Implantation of Tibial Prosthesis

Bone cement should be applied to the prosthesis and prepared bone surfaces when the cement has a viscosity low enough to promote good penetration into the trabecular bone.

Apply bone cement to the proximal tibia and the distal surface of the tibial tray component, including the stem, using either a cement gun or by manually pressurizing the cement. Assure that both the bone and the bone-side of the prosthesis are thoroughly coated with cement. When using the finned tray components, ensure that cement is pressed into the cement pockets (undercuts) (Figures 65, 66 and 67). Care should be taken to limit the amount of cement placed on the posterior lateral corner of the implant to limit cement cleanup in the posterior capsule.

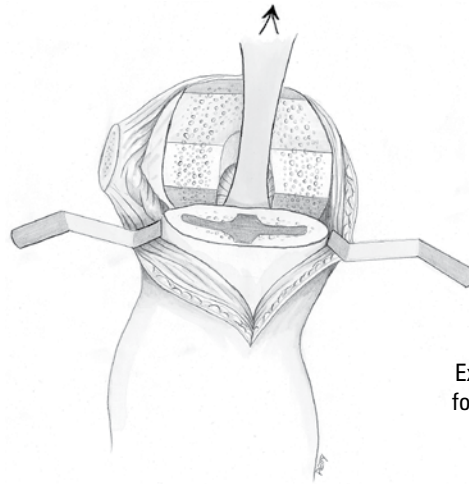

Figure 64
Exposure of Proximal Tibia
for Prosthesis Implantation

Figure 65
Cement Pressed Into
Cement Pockets

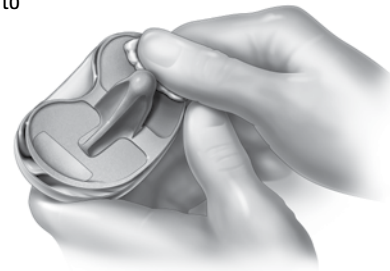

Figure 66
Tray Thoroughly Coated
with Cement

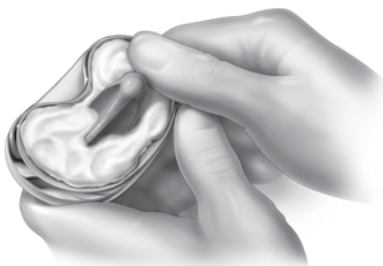
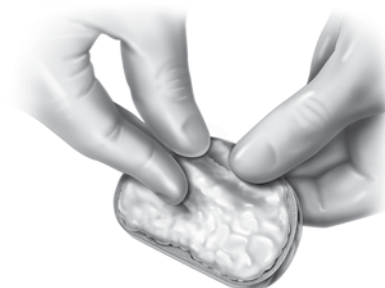

Figure 67
Stem Thoroughly Coated
with Cement



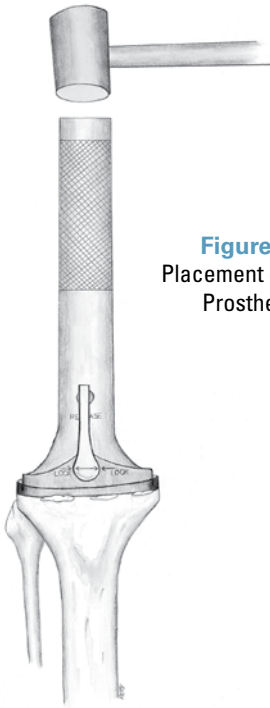

Figure 68
Placement of Tibial
Prosthesis



Figure 69
Installation of
Polyethylene Insert



Figure 70
Insertion of Pre-Assembled
or All-Polyethylene Tibial
Component

Introduce the tibial tray component onto the prepared tibial surface using the **Locking Tibial Tray Impactor**, applying a constant downward force (*Figure 68*). Alternately, the polyethylene insert may be assembled to the tibial tray prior to implantation. In this case, the **Tibial Insert Impactor** should be used to insert the pre-assembled components (*Figure 69*). A mallet can be used for final impaction of the tibial component. All extraneous cement must be removed from the borders of the tibial component, starting posteriorly and working around to the sides and front. All cement must be removed from the posterior capsular area of the knee.

A Tibial Insert Trial should be used when pressurizing the cement during polymerization unless the polyethylene insert was pre-assembled to the tray before implantation. It is recommended to install the final insert implant after the cement has polymerized. The all-polyethylene or metal-backed tibial component may be used instead of a modular component, in which case the implantation technique is similar to the pre-assembled modular tibial component (*Figure 70*).

Step 3: Implantation of Femoral Component

It is important to apply bone cement to both the resected femoral bone surface and the bone mating surface of the femoral component. Take care to apply only a thin layer of cement on the posterior surface of the prosthesis in order to avoid excessive cement extrusion posteriorly where it could be difficult to remove (*Figure 71*). Apply bone cement to the anterior, chamfer and distal surfaces of the prepared femur. Avoid placing cement on the posterior bone surface to prevent excessive cement extrusion posteriorly (*Figure 72*).

The femoral component should be positioned onto the distal femur by using the Locking Femoral Impactor. Slight upward pressure should be applied to the Impactor handle as the component is being impacted to prevent it from rotating into flexion. The **Non-Locking Femoral Impactor** can be used for final impaction of the femoral prosthesis (*Figure 73*). All cement must be removed from the posterior capsular area of the knee.

Step 4: Implantation of Patellar Component

The patellar surface should be coated with cement and the patellar component implanted. The surgeon should take care to align the peg(s) with the previously drilled peg hole(s) (*Figure 74*).

The patella should be held securely with the Patellar Cement Clamp (*Figure 75*). The surgeon should avoid excessive pressure with the Patellar Cement Clamp as it may damage the patella, especially when the bone is soft. Remove excess cement.

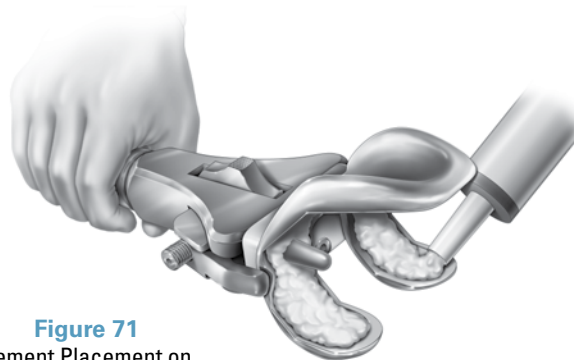

Figure 71
Cement Placement on
Femoral Component

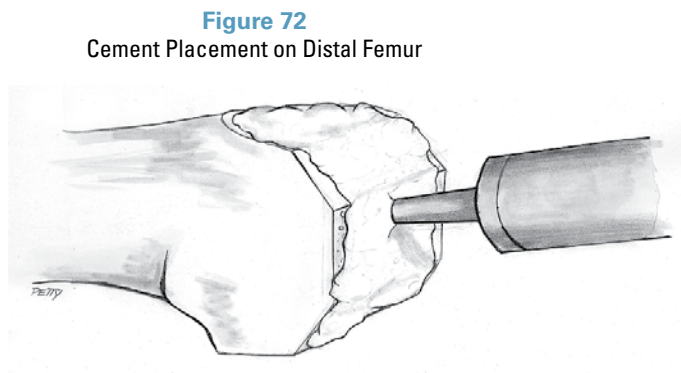

Figure 72
Cement Placement on Distal Femur

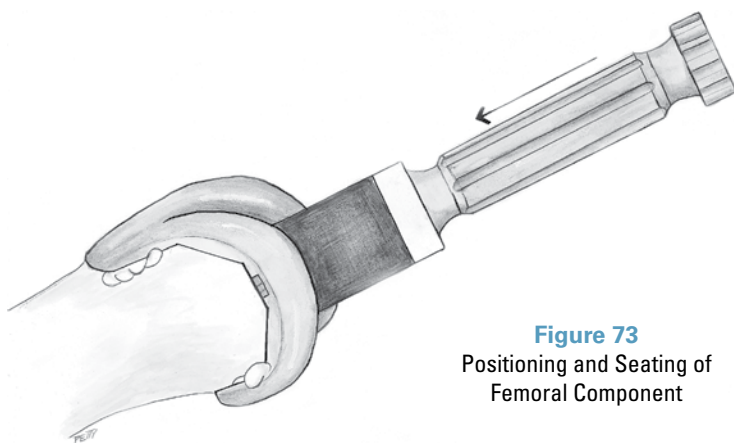

Figure 73
Positioning and Seating of
Femoral Component

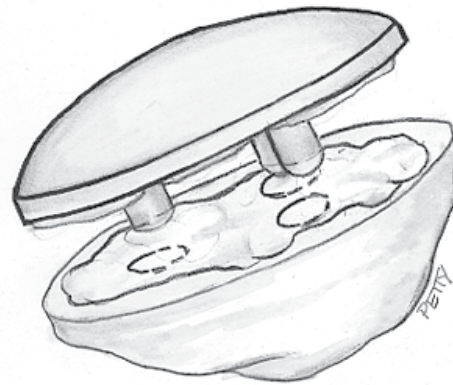
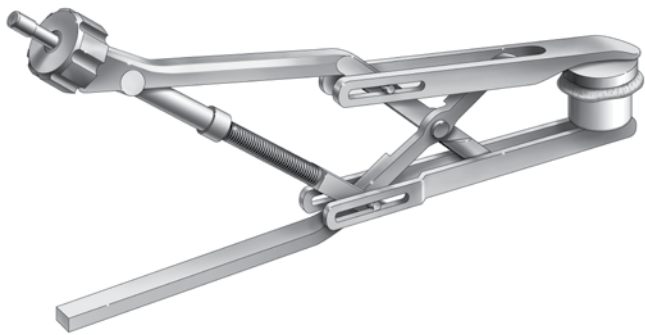

Figure 74
Implantation of Patellar
Prosthesis

Figure 75
Secure Patellar Prosthesis
with Patellar Cement Clamp



Step 5: Polymerization of Cement

Hold axial pressure across the joint during cement polymerization, avoiding either hyperextension or flexion which may tip the prosthesis into either flexion or extension (*Figure 76*). This is important in every case, but especially in osteopenic bone. Avoid any movement of the prosthesis until the bone cement has completely polymerized.

Step 6: Installation of Tibial Polyethylene Insert

(modular tibial component only)

After the cement has completely polymerized, the tibial polyethylene insert should be directed posteriorly so that the posterior portion slides under the rail of the metal tibial tray. Using the **Tibial Component Impactor**, the polyethylene insert should be impacted with a sharp blow from a mallet. The surgeon should check to be certain that the insert is fully seated in the metal tibial tray.

FINAL CHECK AND CLOSURE

Final check includes the following:

1. Removal of any remaining extruded cement

2. Final assessment of:

ALIGNMENT,
STABILITY,
MOTION and
PATELLARTRACKING







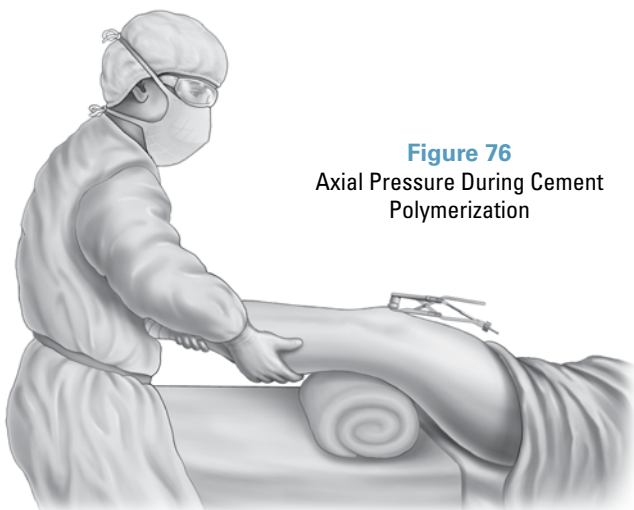



Closure:

A standard closure technique preferred by the surgeon may be used.

Figure 76
Axial Pressure During Cement
Polymerization



INSTRUMENT LISTING

Catalog Number	Part Description	
201-40-00	Intra-medullary Pilot Drill, Hudson	
201-41-00	T-Handle Intra-medullary Rod	
201-42-00	Intra-medullary Femoral Alignment Guide	
201-43-00	Distal Femoral Resection Guide	
201-44-00	Mauldin Multi-Tool	
201-45-00	1/8" Drill Bit	
201-47-00 201-47-10	Femoral A/P Sizer, Size 1-6 Femoral A/P Sizer, Size 0-6 [†]	
201-48-00	Drill Bushing, 0 degrees	
201-49-01	Drill Bushing, 3 degrees	
201-50-00	A/P Sizer Collar Drill, 4mm	

Catalog Number

Part Description

- 201-51-10 Femoral Finishing Guide, Size 0
- 201-51-11 Femoral Finishing Guide, Size 1
- 201-51-12 Femoral Finishing Guide, Size 2
- 201-51-13 Femoral Finishing Guide, Size 3
- 201-51-14 Femoral Finishing Guide, Size 4
- 201-51-15 Femoral Finishing Guide, Size 5
- 201-51-16 Femoral Finishing Guide, Size 6



Extra-medullary Tibial Alignment Guide

- 201-52-00 Tibial Ankle Clamp



- 201-52-02 Adjustable Tibial Resector Shaft, Extra-medullary



- 201-53-00 Tibial Stylus, Fixed



- 201-54-00 Tibial Resection Guide, Slotted
- 201-54-02 Tibial Resection Guide, Slotted, 5-Degree Posterior Slope



- 201-58-01 Extra-medullary Alignment Rod/Coupler



- 201-58-02 Extra-medullary Alignment Rod



- 201-60-00 Patellar Drill Guide



- 201-61-01 One-Peg Patellar Drill, Hudson



- 201-61-03 Three-Peg Patellar Drill, Standard Hudson



- 201-62-00 Patellar Cement Clamp



INSTRUMENT LISTING

Catalog Number Part Description

201-62-02 Slotted Patellar Resection Guide, Bishop

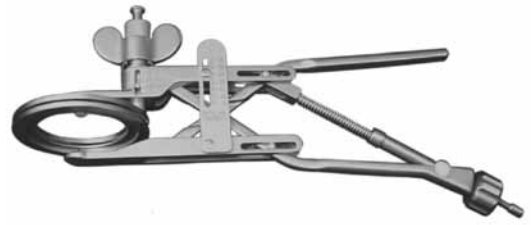

201-64-00 Femoral Impactor, Non-Locking



213-64-01 Locking Femoral Impactor



201-65-00 Locking Tibial Tray Impactor, Size 1-6
201-65-10 Locking Tibial Tray Impactor, Size 0-6



201-69-01 Pin Puller



201-71-00 Tibial Pilot Drill Guide



201-72-00 Tibial Tamp, Finned, Net-Shape, Size 1-6
201-72-10 Tibial Tamp, Finned, Net-Shape, Size 0-6



201-73-00 Tibial Tamp, Trapezoid



Catalog Number**Part Description**

201-74-00
201-74-10

Tibial Tamp Guide, Size 1-6
Tibial Tamp Guide, Size 0-6



201-85-00

Resection Guide Handles



201-89-00

Intra-medullary Tibial Alignment Guide, Adjustable



201-90-00

Tibial Component Impactor



201-90-01

Tibial Insert Impactor



205-53-01
205-53-02
205-53-03
205-53-04
205-53-05

LPI Femoral Box Resection Guide, PS, Size 1
LPI Femoral Box Resection Guide, PS, Size 2
LPI Femoral Box Resection Guide, PS, Size 3
LPI Femoral Box Resection Guide, PS, Size 4
LPI Femoral Box Resection Guide, PS, Size 5



213-53-00
213-53-01
213-53-02
213-53-03
213-53-04
213-53-05
213-53-06

LPI Beta PS Notch Guide, Size 0†
LPI Beta PS Notch Guide, Size 1
LPI Beta PS Notch Guide, Size 2
LPI Beta PS Notch Guide, Size 3
LPI Beta PS Notch Guide, Size 4
LPI Beta PS Notch Guide, Size 5
LPI Beta PS Notch Guide, Size 6†



213-77-00

Cut Line Predictor

INSTRUMENT LISTING

Catalog Number	Part Description
201-01-00	Femoral Trial, CR, Size 0*†
201-01-01	Femoral Trial, CR, Size 1*
201-01-02	Femoral Trial, CR, Size 2*
201-01-03	Femoral Trial, CR, Size 3*
201-01-04	Femoral Trial, CR, Size 4*
201-01-05	Femoral Trial, CR, Size 5*
201-01-06	Femoral Trial, CR, Size 6*†
205-01-10	Femoral Trial, PS, Size 0*†
205-01-11	Femoral Trial, PS, Size 1*
205-01-12	Femoral Trial, PS, Size 2*
205-01-13	Femoral Trial, PS, Size 3*
205-01-14	Femoral Trial, PS, Size 4*
205-01-15	Femoral Trial, PS, Size 5*
205-01-16	Femoral Trial, PS, Size 6*†
201-02-26	Three-Peg Patella Trial, Size 26
201-02-29	Three-Peg Patella Trial, Size 29
201-02-32	Three-Peg Patella Trial, Size 32
201-02-35	Three-Peg Patella Trial, Size 35
201-02-38	Three-Peg Patella Trial, Size 38
201-02-41	Three-Peg Patella Trial, Size 41
201-80-09	Tibial Trial, Modular Insert, Size 0, 9mm†
201-80-11	Tibial Trial, Modular Insert, Size 0, 11mm†
201-80-13	Tibial Trial, Modular Insert, Size 0, 13mm†
201-80-15	Tibial Trial, Modular Insert, Size 0, 15mm†
201-80-18	Tibial Trial, Modular Insert, Size 0, 18mm†
201-81-09	Tibial Trial, Modular Insert, Size 1 Delta, 9mm
201-81-11	Tibial Trial, Modular Insert, Size 1 Delta, 11mm
201-81-13	Tibial Trial, Modular Insert, Size 1 Delta, 13mm
201-81-15	Tibial Trial, Modular Insert, Size 1 Delta, 15mm
201-81-18	Tibial Trial, Modular Insert, Size 1 Delta, 18mm
201-81-22	Tibial Trial, Modular Insert, Size 1 Delta, 22mm
201-81-26	Tibial Trial, Modular Insert, Size 1 Delta, 26mm
201-81-30	Tibial Trial, Modular Insert, Size 1 Delta, 30mm
201-21-09	Tibial Trial, Modular Insert, Size 1, 9mm
201-21-11	Tibial Trial, Modular Insert, Size 1, 11mm
201-21-13	Tibial Trial, Modular Insert, Size 1, 13mm
201-21-15	Tibial Trial, Modular Insert, Size 1, 15mm
201-21-18	Tibial Trial, Modular Insert, Size 1, 18mm
201-21-22	Tibial Trial, Modular Insert, Size 1, 22mm†
201-21-26	Tibial Trial, Modular Insert, Size 1, 26mm†
201-21-30	Tibial Trial, Modular Insert, Size 1, 30mm†
201-22-09	Tibial Trial, Modular Insert, Size 2, 9mm
201-22-11	Tibial Trial, Modular Insert, Size 2, 11mm
201-22-13	Tibial Trial, Modular Insert, Size 2, 13mm



201-22-15	Tibial Trial, Modular Insert, Size 2, 15mm
201-22-18	Tibial Trial, Modular Insert, Size 2, 18mm
201-22-22	Tibial Trial, Modular Insert, Size 2, 22mm†
201-22-26	Tibial Trial, Modular Insert, Size 2, 26mm†
201-22-30	Tibial Trial, Modular Insert, Size 2, 30mm†
201-23-09	Tibial Trial, Modular Insert, Size 3, 9mm
201-23-11	Tibial Trial, Modular Insert, Size 3, 11mm
201-23-13	Tibial Trial, Modular Insert, Size 3, 13mm
201-23-15	Tibial Trial, Modular Insert, Size 3, 15mm
201-23-18	Tibial Trial, Modular Insert, Size 3, 18mm
201-23-22	Tibial Trial, Modular Insert, Size 3, 22mm†
201-23-26	Tibial Trial, Modular Insert, Size 3, 26mm†
201-23-30	Tibial Trial, Modular Insert, Size 3, 30mm†
201-24-09	Tibial Trial, Modular Insert, Size 4, 9mm
201-24-11	Tibial Trial, Modular Insert, Size 4, 11mm
201-24-13	Tibial Trial, Modular Insert, Size 4, 13mm
201-24-15	Tibial Trial, Modular Insert, Size 4, 15mm
201-24-18	Tibial Trial, Modular Insert, Size 4, 18mm
201-24-22	Tibial Trial, Modular Insert, Size 4, 22mm†
201-24-26	Tibial Trial, Modular Insert, Size 4, 26mm†
201-24-30	Tibial Trial, Modular Insert, Size 4, 30mm†
201-25-09	Tibial Trial, Modular Insert, Size 5, 9mm
201-25-11	Tibial Trial, Modular Insert, Size 5, 11mm
201-25-13	Tibial Trial, Modular Insert, Size 5, 13mm
201-25-15	Tibial Trial, Modular Insert, Size 5, 15mm
201-25-18	Tibial Trial, Modular Insert, Size 5, 18mm
201-25-22	Tibial Trial, Modular Insert, Size 5, 22mm†
201-25-26	Tibial Trial, Modular Insert, Size 5, 26mm†
201-25-30	Tibial Trial, Modular Insert, Size 5, 30mm†
201-26-11	Tibial Trial, Modular Insert, Size 6, 11mm†
201-26-13	Tibial Trial, Modular Insert, Size 6, 13mm†
201-26-15	Tibial Trial, Modular Insert, Size 6, 15mm†
201-26-18	Tibial Trial, Modular Insert, Size 6, 18mm†
201-26-22	Tibial Trial, Modular Insert, Size 6, 22mm†
201-26-26	Tibial Trial, Modular Insert, Size 6, 26mm†
201-26-30	Tibial Trial, Modular Insert, Size 6, 30mm†
213-70-00	LPI Tibial Tray Trial, Size 0†
213-70-10	LPI Tibial Tray Trial, Size 1
213-70-20	LPI Tibial Tray Trial, Size 2
213-70-30	LPI Tibial Tray Trial, Size 3
213-70-40	LPI Tibial Tray Trial, Size 4
213-70-50	LPI Tibial Tray Trial, Size 5
213-70-60	LPI Tibial Tray Trial, Size 6†
205-52-00	Tibial Trial, PS Spine, Size 0†
205-52-01	Tibial Trial, PS Spine, Size 1
205-52-02	Tibial Trial, PS Spine, Size 2
205-52-03	Tibial Trial, PS Spine, Size 3
205-52-04	Tibial Trial, PS Spine, Size 4
205-52-05	Tibial Trial, PS Spine, Size 5
205-52-06†	Tibial Trial, PS Spine, Size 6†



REFERENCES

1. **Scuderi GR, Insall JN, Windsor RE, Moran MC.** Survivorship of cemented knee replacements. *J Bone Joint Surg Br.* 1989 Nov;71(5):798-803.
2. **Stern SH, Insall JN.** Posterior stabilized prosthesis. Results after follow-up of nine to twelve years. *J Bone Joint Surg Am.* 1992 Aug;74(7):980-6.
3. **Ranawat CS, Boachie-Adjei O.** Survivorship analysis and results of total condylar knee arthroplasty. Eight- to 11-year follow-up period. *Clin Orthop Relat Res.* 1988 Jan;(226):6-13.
4. **Bartel DL, Bicknell VL, Wright TM.** The effect of conformity, thickness, and material on stresses in ultra-high molecular weight components for total joint replacement. *J Bone Joint Surg Am.* 1986 Sep;68(7):1041-51.
5. **Bartel DL, Rawlinson JJ, Burstein AH, Ranawat CS, Flynn WF Jr.** Stresses in polyethylene components of contemporary total knee replacements. *Clin Orthop Relat Res.* 1995 Aug;(317):76-82.
6. Patello-femoral resistance to lateral subluxation, contact areas and surface stress of the Exactech total knee system. A pre-market analysis. Mt. Sinai Medical Center. Orthopaedic Research Laboratories. 1994.
7. **Miller GJ.** The effect of TKA congruity and alignment on contact pressure. Proceedings of the 59th Annual Current Concepts in Joint Replacement Meeting; 1994 Orlando, Fla.
8. **Petty RW.** Caveats in patello-femoral design. Proceedings of the 10th Annual Current Concepts in Joint Replacement Meeting; 1994 Orlando, Fla.
9. **Ray JD.** Comparison of tibial tray shape coverage of proximal tibia. Poster presented at the 61st Annual American Academy of Orthopaedic Surgeons Meeting; 1994 New Orleans, La.
10. **Robinson RP.** Five-year follow-up of primary Optetrak Posterior Stabilized total knee arthroplasties in osteoarthritis. *J Arthroplasty.* 2005 Oct;20(7):927-31.

For additional device information, refer to the Exactech Optetrak® Comprehensive Knee System – Instructions for Use.

For further product information, please contact Customer Service, Exactech, Inc. 2320 NW 66th Court, Gainesville, Florida 32653-1630, USA. (352) 377-1140, (800) 392-2832 or FAX (352) 378-2617.

Authorized European Representative

MediMark® Europe
11, rue Emile Zola B.P. 2332
38033 Grenoble Cedex 2
France

US Patents 5,732,992; 5,688,281; 5,910,143; 6,193,723B1; 5,725,580; 4,298,992; 5,702,458.
Other US and foreign patents pending.

Exactech is proud to have offices and distributors around the globe.

For more information about Exactech products available in your country, please visit www.exac.com

©2010 Exactech, Inc. • ISO 13485 Certified

352-377-1140
1-800-EXACTECH
www.exac.com



712-01-30 Rev. D
CRPS Operative Technique 1010



A Great Day in the O.R.™